



MUCH ADO  
ABOUT NOTHING

Arizona Repertory Theatre  
2023-2024 Season  
*Blocking Book*

*Kathryn Kulaga*

*Stage Manager*



DP.....DON PEDRO  
BEN.....BENEDICK  
CLA.....CLAUDIO  
LEO.....LEONATA  
ANT.....ANTONIA  
HO.....HERO  
BEA.....BEATRICE  
URS.....URSULA  
MAR.....MARGARET  
DJ.....DON JOHN  
CON.....CONRADE  
BOR.....BORACHIO  
BAL.....BALTHASAR  
FRY.....FRIAR  
SEX.....SEXTON  
DOG.....DOGBERRY  
VER.....VERGES  
GS.....GEORGE SEACOLE  
OAT.....HUGH OATCAKE  
AC.....AGNES CHEDDAR

ENT.....ENTER  
EX.....EXIT  
X.....CROSS  
SL.....STAGE LEFT  
SR.....STAGE RIGHT  
P/U.....PICK UP  
P/D.....PUT DOWN  
ñ .....CROSS US OF  
u .....CROSS DS OF

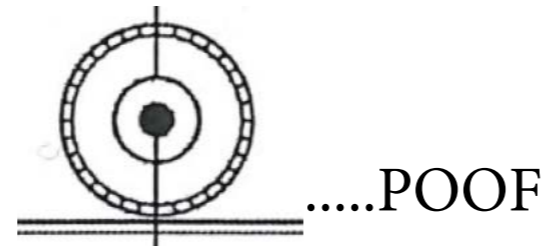

Much Ado About Nothing

ACT I, SCENE I

Before LEONATA'S house.

LEONATA

1. I learn in this letter that Don Pedro of Aragon comes this night to Messina.

BALTHASAR

2. He is very near by this: he was not three leagues off when I left him.

LEONATA

How many soldiers have you lost in this action?

BALTHASAR

But few of any sort, and none of name.

LEONATA

A victory is twice itself when the achiever brings home full numbers. I find here that Don Pedro hath bestowed much honour on a young Florentine called Claudio.

BALTHASAR

Much deserved on his part and equally remembered by Don Pedro: he hath borne himself beyond the promise of his age, doing, in the figure of a lamb, the feats of a lion: he hath indeed better bettered expectation than you must expect of me to tell you how.

BEATRICE

3. I pray you, is Signior Mountanto returned from the wars or no?

BALTHASAR

4. I know none of that name, lady: there was none such in the army of any sort.

LEONATA

What is he that you ask for, niece?

HERO

My cousin means Signior Benedick of Padua.

BALTHASAR

O, he's returned; and as pleasant as ever he was.

BEATRICE

3. I pray you, how many hath he killed and eaten in these wars? But how many hath he killed? for indeed I promised to eat all of his killing.

LEONATA

Faith, niece, you tax Signior Benedick too much; but he'll be meet with you, I doubt it not.

BALTHASAR

5. He hath done good service, lady, in these wars. 6.

BEATRICE

Act I

Much Ado About Nothing

TOS: BEA ent DSR, sit SR

URS/MAR ent DSL, sit fount

1. LEO, BAL, HO, ANT ent

SR esc, LEO x to buldge

2. URS/MAR put magazines away

3. BEA stand

4. BAL step DC

5. BAL x SR, step 4 down

6. BEA x CS, sit on peof

3 girls ent before preshow announce

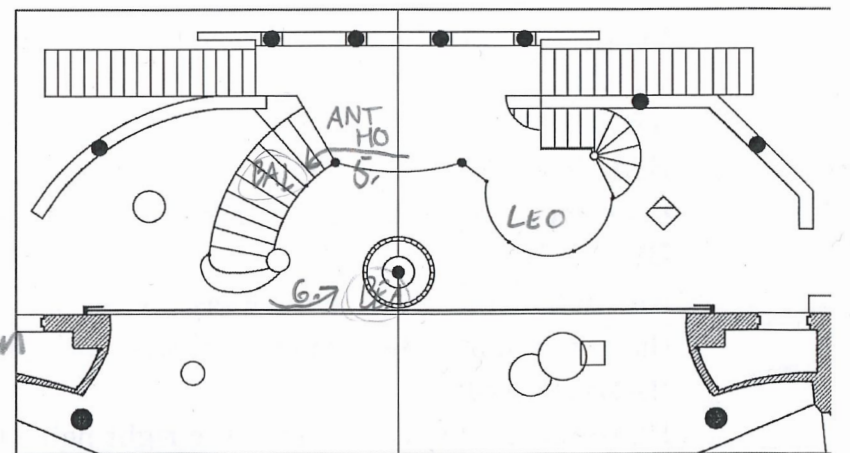
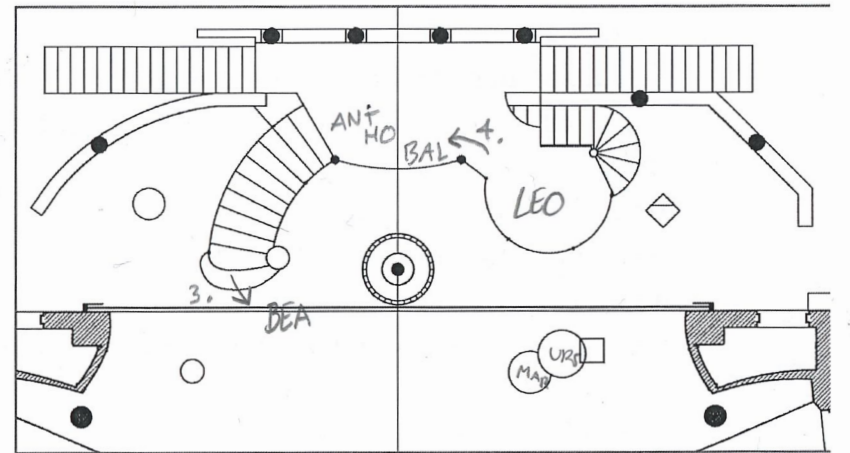
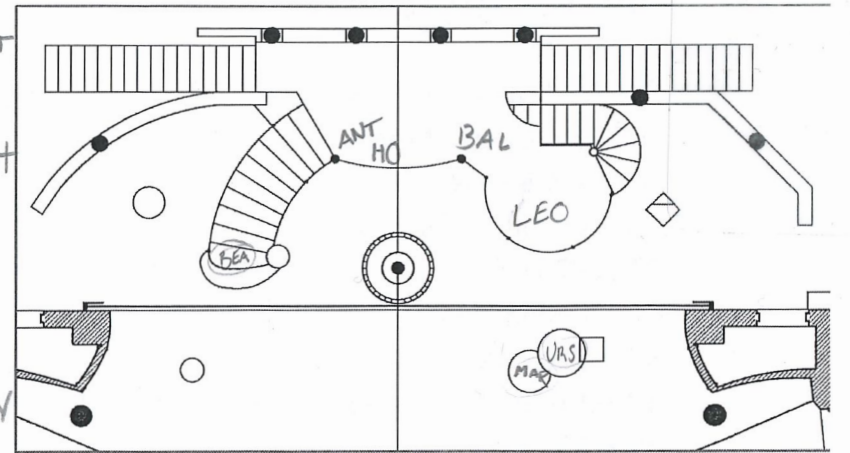

Scene I



*Much Ado About Nothing*

You had musty victual, and he hath help to eat it: he is a very valiant trencherman; he hath an excellent stomach.

**BALTHASAR**

And a good soldier too, lady.

**BEATRICE**

And a good soldier to a lady: but what is he to a lord?

**BALTHASAR**

① A lord to a lord, a man to a man; stuffed with all honourable virtues.

**BEATRICE**

It is so, indeed; he is no less than a stuffed man: but for the stuffing,--well, we are all mortal.

**LEONATA**

② You must not, ma'am, mistake my niece. There is a kind of merry war betwixt Signior Benedick and her: they never meet but there's a skirmish of wit between them.

**BEATRICE**

Alas! he gets nothing by that. In our last conflict four of his five wits went halting off, and

now is the whole man governed with one. Who is his companion now? He hath every month a new sworn brother.

**BALTHASAR**

Is't possible?

**BEATRICE**

Very easily possible: he wears his faith but as the fashion of his hat; it ever changes with the next block.

**BALTHASAR**

I see, lady, the gentleman is not in your books.

**BEATRICE**

No; an he were, I would burn my study. But, I pray you, who is his companion? Is there no young squarer now that will make a voyage with him to the devil?

**BALTHASAR**

He is most in the company of the right noble Claudio.

**BEATRICE**

O Lord, he will hang upon him like a disease: he is sooner caught than the pestilence, and the taker runs presently mad. God help the noble Claudio! if he have caught the Benedick, it will cost him a thousand pound ere a' be cured.

**BALTHASAR**

I will hold friends with you, lady.

I + JA

*Much Ado About Nothing*

1. BAL cont ↓ to floor

2. LEO x to HO

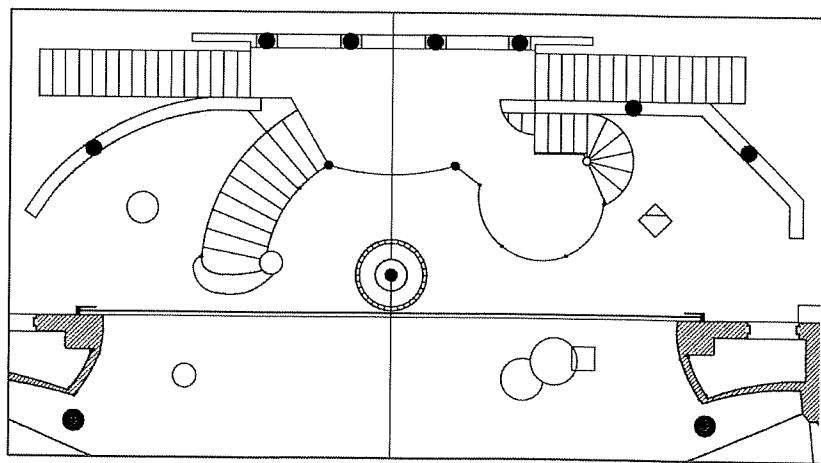
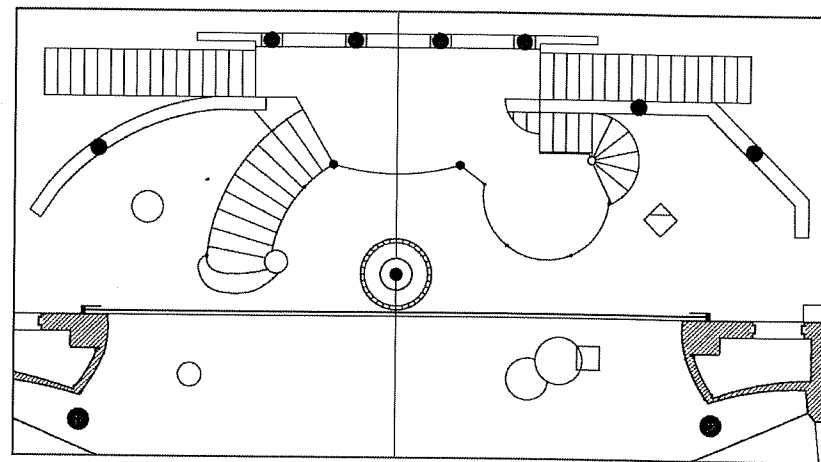
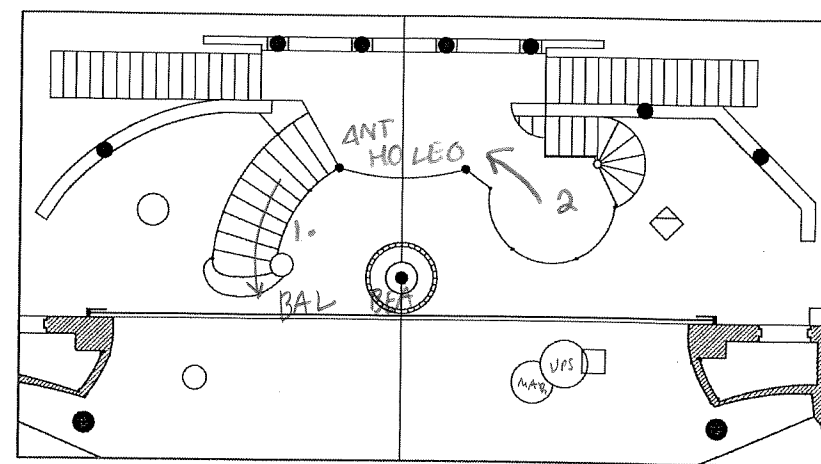

Scene II



Much Ado About Nothing

BEATRICE

1. Do, good friend.

LEONATA

You will never run mad, niece.

BEATRICE

No, not till a hot January. — Military cue

BALTHASAR

3,4 Don Pedro is approached.

Enter DON PEDRO, DON JOHN, CLAUDIO and BENEDICK

DON PEDRO — curtsied

Good Signiora Leonata, you are come to meet your trouble: the fashion of the world is to avoid cost, and you encounter it.

LEONATA

Never came trouble to my house in the likeness of your grace: for trouble being gone, comfort should remain; but when you depart from me, sorrow abides and happiness takes his leave.

DON PEDRO

5. You embrace your charge too willingly. I think this is your daughter. Be happy, lady; for you are like an honourable mother. 6.

BENEDICK

7. If Signiora Leonata be her mother, she would not have her cares and responsibilities for all Messina, as like her as she is.

BEATRICE

8. I wonder that you will still be talking, Signior Benedick: nobody marks you.

BENEDICK

What, my dear Lady Disdain! are you yet living?

BEATRICE

Is it possible disdain should die while she hath such meet food to feed it as Signior Benedick? Courtesy itself must convert to disdain, if you come in her presence.

BENEDICK

Then is courtesy a turncoat. But it is certain I am loved of all ladies, only you excepted: and I would I could find in my heart that I had not a hard heart; for, truly, I love none.

BEATRICE

9. A dear happiness to women: they would else have been troubled with a pernicious suitor. I thank God and my cold blood, I am of your humour for that: I had rather hear my dog bark at a crow than a man swear he loves me.

Much Ado About Nothing

1. BEA stand, x to BAL

2. DP, DJ, CLA, BEN, BOR

CON eat House Right

3. BAL x DSL, greet!

4. LEO, HO, ANT x ↓ SR, MAR/URS x UC under plat, BEA x UCR

5. DP step SR, LEO step US, present HO

6. DP, LEO, HO, ANT x SR

7. BEN x DC

8. BEA x DC

9. BEA slow clap, BEN to SL, BEN O BEA to SL

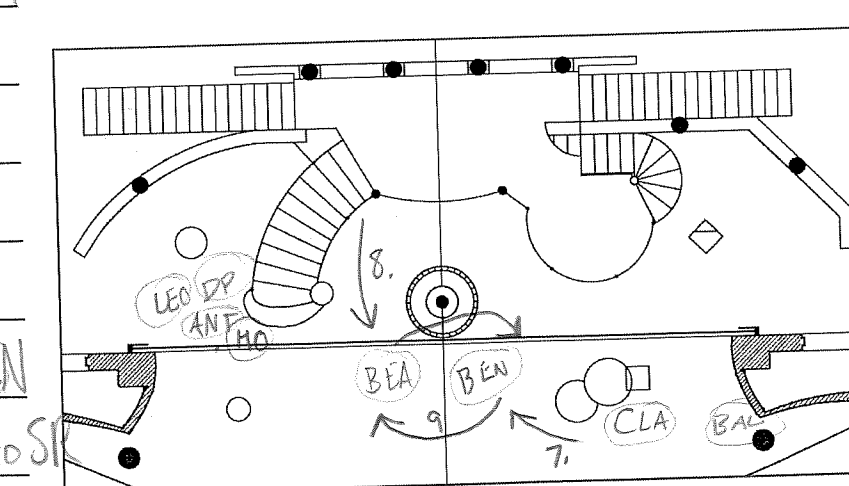
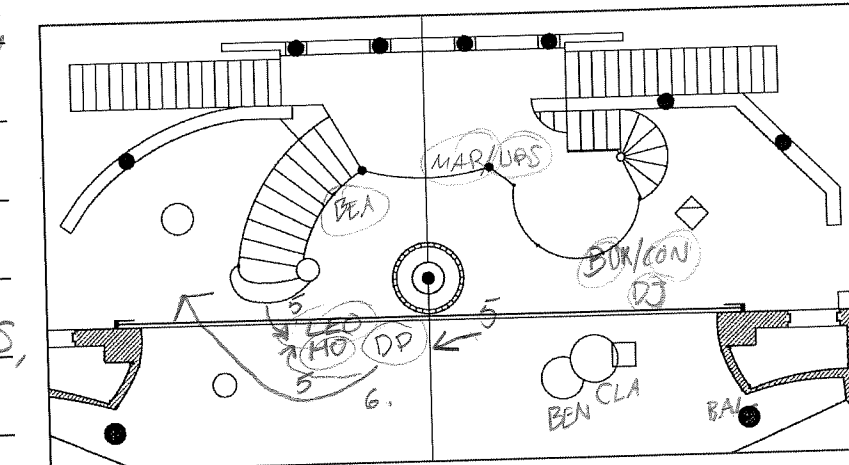
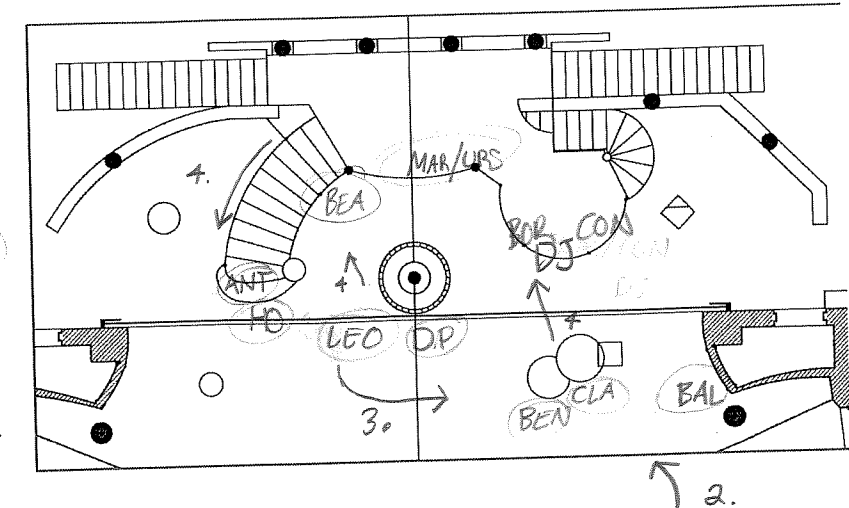

Scene II



Much Ado About Nothing

BENEDICK

1. God keep your ladyship still in that mind! so some gentleman or other shall 'scape a predestinate scratched face.

BEATRICE

Scratching could not make it worse, an 'twere such a face as yours were.

BENEDICK

Well, you are a rare parrot-teacher.

BEATRICE

A bird of my tongue is better than a beast of yours.

BENEDICK

I would my horse had the speed of your tongue, and so good a continuer. But keep your way, i' God's name: I have done.

BEATRICE

You always end with a jade's trick: I know you of old. 2

DON PEDRO

4 That is the sum of all, Leonata. Signior Claudio and Signior Benedick, my dear friend Leonata hath invited you all. I tell her we shall stay here at the least a month; and she heartily prays some occasion may detain us longer. I dare swear she is no hypocrite, but prays from her heart.

LEONATA

If you swear, my lord, you shall not be forsworn. 3

To DON JOHN

Let me bid you welcome, my lord: being reconciled to the prince your brother, I owe you all duty. 5

DON JOHN

I thank you: I am not of many words, but I thank you. 6

LEONATA

Please it your grace lead on?

DON PEDRO

Your hand, Leonata; we will go together. 7

Exeunt all except BENEDICK and CLAUDIO

CLAUDIO

8 Benedick, didst thou note the daughter of Signiora Leonata?

BENEDICK

I noted her not; but I looked on her. 9

Much Ado About Nothing

1. BEA U BEN, BEN U BEA



2. BEN x DSL

3. BEA x USR

4. LEO & DP x DSR

ANT: HO follow

5. LEO U DP, DS of pool

6. DJ step DC

7. LEO, DP, HO, ANT, MAR,

URS, BOR, CON →, ex

USR

DJ ex USL

8. BEN stand, x UCL to

ex, CLA follow, catch BEN

9. CLA/BEN x DSL to fount

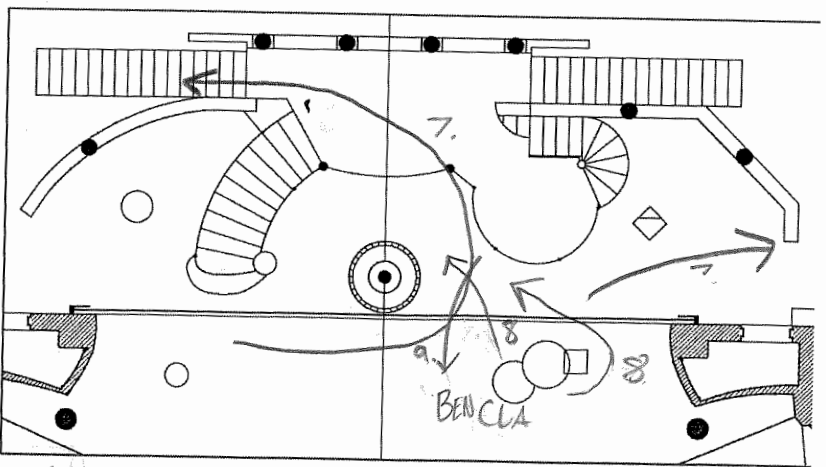
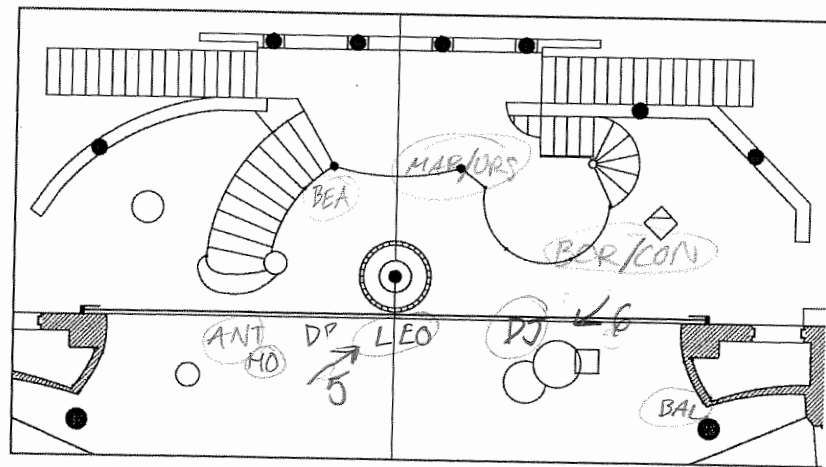
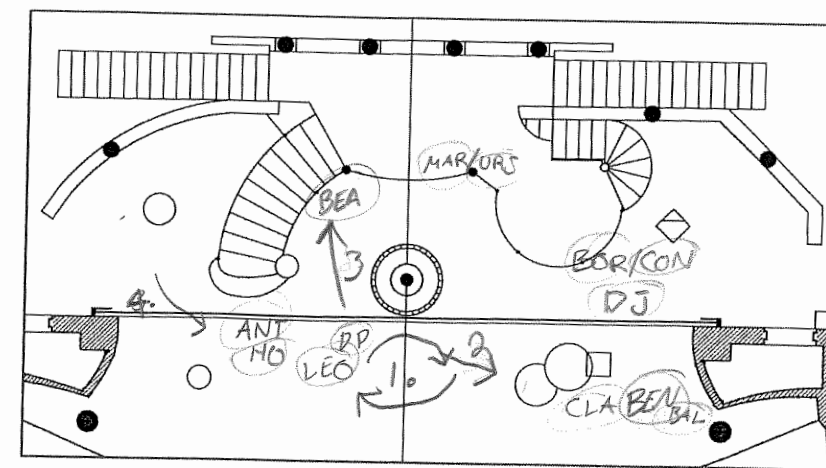

Scene II



*Much Ado About Nothing*

**CLAUDIO**

Is she not a modest young lady?

**BENEDICK**

Do you question me, as an honest man should do, for my simple true judgment; or would you have me speak after my custom, as being a professed tyrant to their sex?

**CLAUDIO**

No; I pray thee speak in sober judgment.

**BENEDICK**

① Why, i' faith, methinks she's too low for a high praise, too high for a common praise and too slim for a great praise: only this commendation I can afford her, that were she other than she is, she were unhandsome; and being no other but as she is, I do not like her. 2.

**CLAUDIO**

③ Thou thinkest I am in sport: I pray thee tell me truly how thou likest her.

**BENEDICK**

Would you buy her, that you inquire after her?

**CLAUDIO**

Can the world buy such a jewel?

**BENEDICK**

Yea, and a case to put it into.

**CLAUDIO**

In mine eye she is the sweetest lady that ever I looked on.

**BENEDICK**

I can see yet without spectacles and I see no such matter: there's her cousin, an she were not possessed with a fury, exceeds her as much in beauty as the first of May doth the last of December. ④ But I hope you have no intent to turn husband, have you? ⑤

**CLAUDIO**

I would scarce trust myself, though I had sworn the contrary, if Hero would be my wife.

**BENEDICK**

⑥ ⑦ Is't come to this? In faith, hath not the world one man but he will wear his cap with suspicion? Shall I never see a bachelor of three-score again? Go to, i' faith; an thou wilt needs thrust thy neck into a yoke, wear the print of it and sigh away Sundays. Look Don Pedro is returned to seek you.

*Re-enter DON PEDRO*

*Much Ado About Nothing*

1. BEN circle ↻ poof

2. BEN sit ↓ poof

3. CLA x to BEN, playful  
arm hit

4. BEN stand, x DSR

5. BEN x to CLA

6. BEN x DSR,  
7. DP ent. USB, x CS

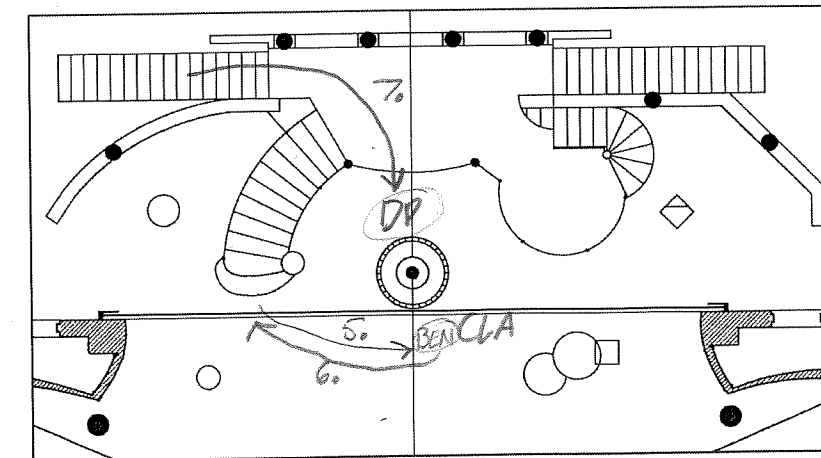
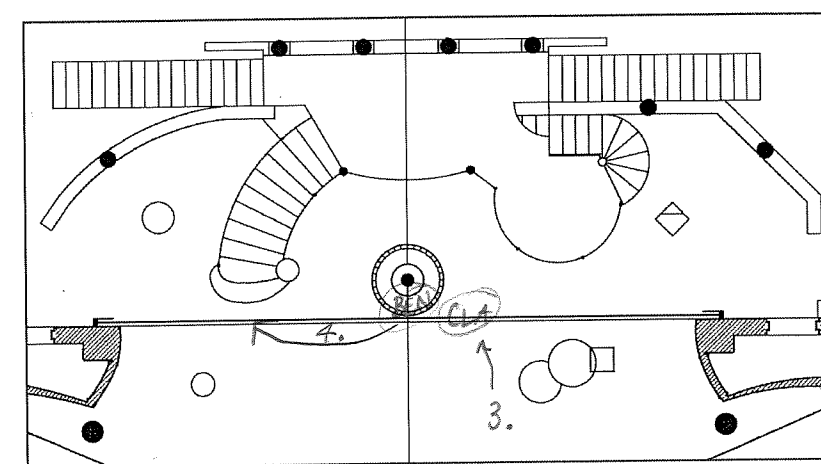
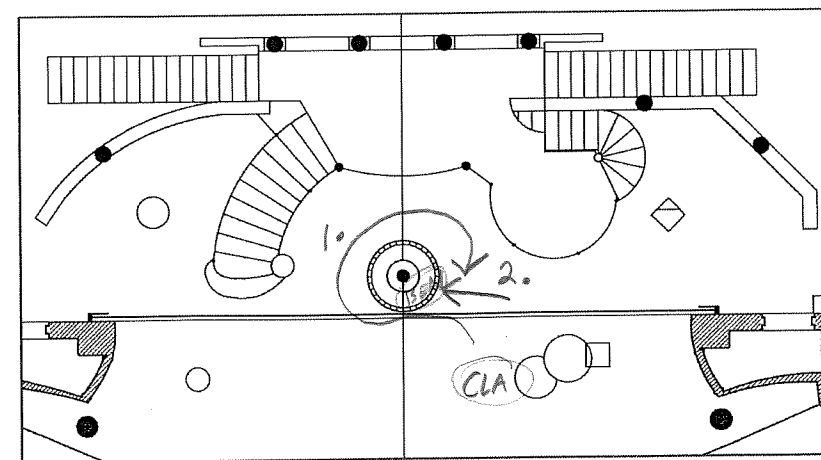

Scene II

is  
atre  
st go



*Much Ado About Nothing*

**DON PEDRO**

1. What secret hath held you here, that you followed not to Leonata's?

**BENEDICK**

I would your grace would constrain me to tell.

**DON PEDRO**

I charge thee on thy allegiance.

**BENEDICK**

You hear, Count Claudio: I can be secret as a dumb man; I would have you think so; but, on my allegiance, mark you this, on my allegiance. He is in love. With who?

2. Now that is your grace's part. Mark how thin his answer is;--With Hero, Leonata's slim daughter.

**CLAUDIO**

If this were so, so were it uttered.

**BENEDICK**

3. Like the old tale, my lord: 'it is not so, nor 'twas not so, but, indeed, God forbid it should be so.'

**CLAUDIO**

If my passion change not shortly, God forbid it should be otherwise.

**DON PEDRO**

Amen, if you love her; for the lady is very well worthy.

**CLAUDIO**

You speak this to fetch me in, my lord.

**DON PEDRO**

By my troth, I speak my thought.

**CLAUDIO**

And, in faith, my lord, I spoke mine.

**BENEDICK**

And, by my two faiths and troths, my lord, I spoke mine.

**CLAUDIO**

That I love her, I feel.

**DON PEDRO**

That she is worthy, I know.

**BENEDICK**

That I neither feel how she should be loved nor know how she should be worthy, is the opinion that fire cannot melt out of me: I will die in it at the stake.

**DON PEDRO**

Thou wast ever an obstinate heretic in the despite of beauty.

*Much Ado About Nothing*

1. DP wander to SL of roof

2. BEN x UC, near DP

3. BEN step in front of DP

4. BEN x DSR, sit on stairs

CLA sit fount.

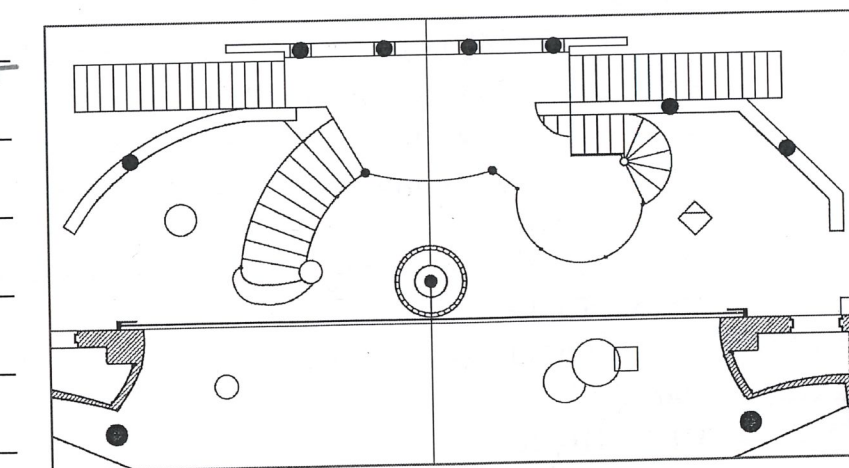
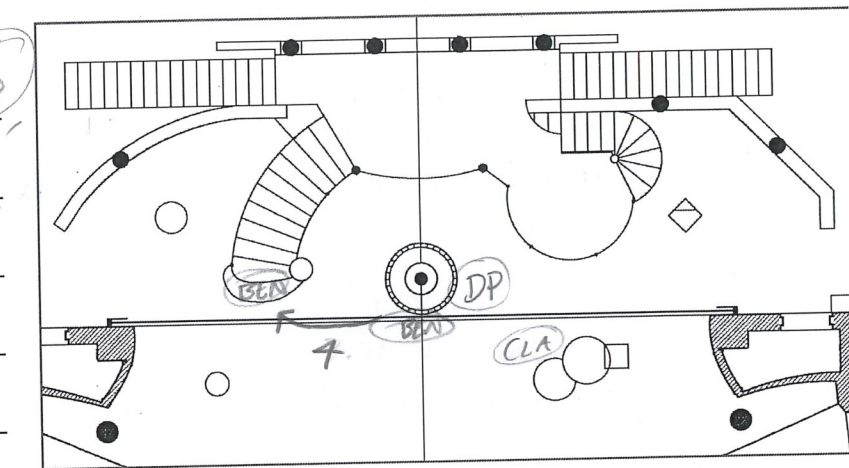
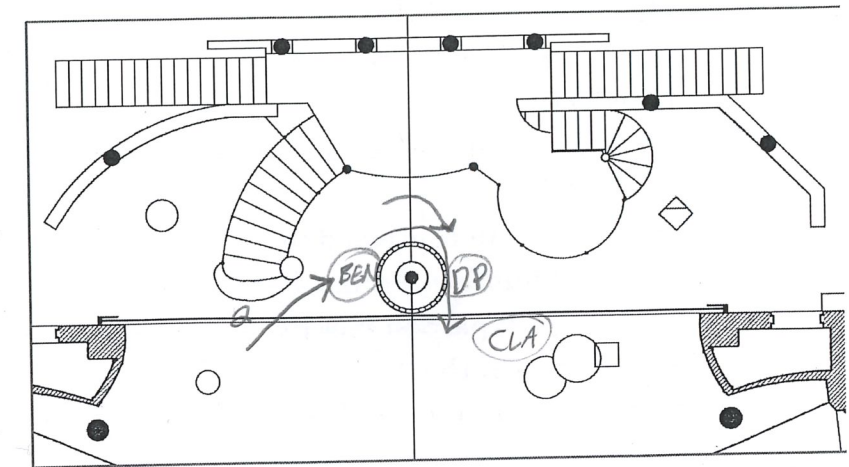

Scene II



*Much Ado About Nothing*

**CLAUDIO**

And never could maintain his part but in the force of his will.

**BENEDICK**

That a woman conceived me, I thank her; that she brought me up, I likewise give her most humble thanks: but that I will hang my bugle in an invisible baldrick, all women shall pardon me. Because I will not do them the wrong to mistrust any, I will do myself the right to trust none; and the fine is, for the which I may go the finer, I will live a bachelor.

**DON PEDRO**

I shall see thee, ere I die, look pale with love.

**BENEDICK**

With anger, with sickness, or with hunger, my lord, not with love: prove that ever I lose more blood with love than I will get again with drinking, pick out mine eyes with a ballad-maker's pen and hang me up at the door of a brothel-house for the sign of blind Cupid.

**DON PEDRO**

2 Well, if ever thou dost fall from this faith, thou wilt prove a notable argument.

**BENEDICK**

If I do, hang me in a bottle like a cat and shoot at me.

**DON PEDRO**

Well, as time shall try: 'In time the savage bull doth bear the yoke.'

**BENEDICK**

The savage bull may; but if ever the sensible Benedick bear it, pluck off the bull's horns and set them in my forehead: and let me be vilely painted, and in such great letters as they write 'Here is good horse to hire,' let them signify under my sign 'Here you may see Benedick the married man.'

**CLAUDIO**

3 If this should ever happen, thou wouldst be horn-mad.

**DON PEDRO**

Nay, if Cupid have not spent all his quiver in Venice, thou wilt quake for this shortly.

**BENEDICK**

I look for an earthquake too, then.

**DON PEDRO**

Well, you temporize with the hours. In the meantime, good Signior Benedick, repair to

4 Leonata's: commend me to her and tell her I will not fail her at supper; for indeed she hath made great preparation.

*Much Ado About Nothing*

When 101

1. BEN stand on stair, step DSR

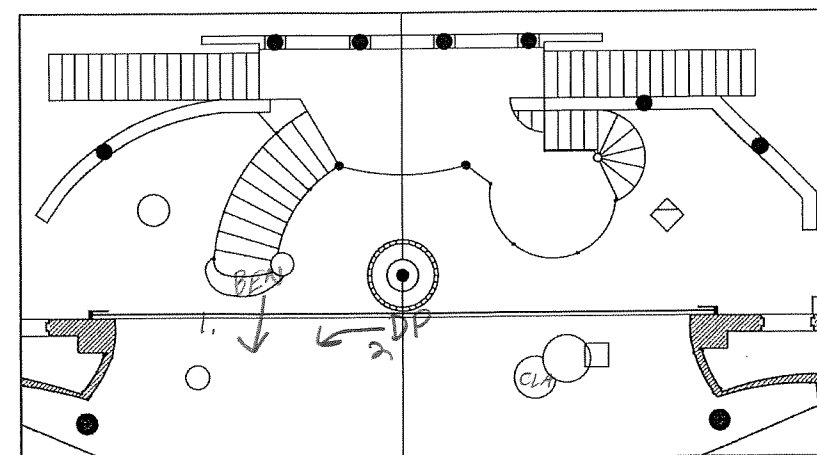

2. DP step DSR, toward BEN

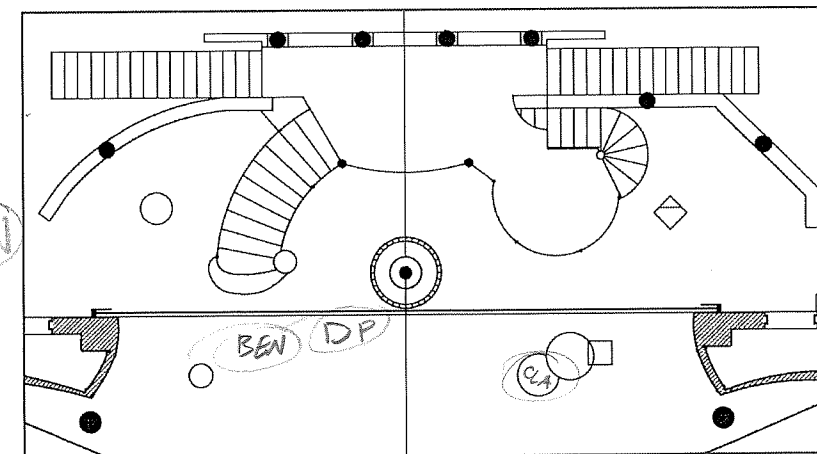

3. CLA stand

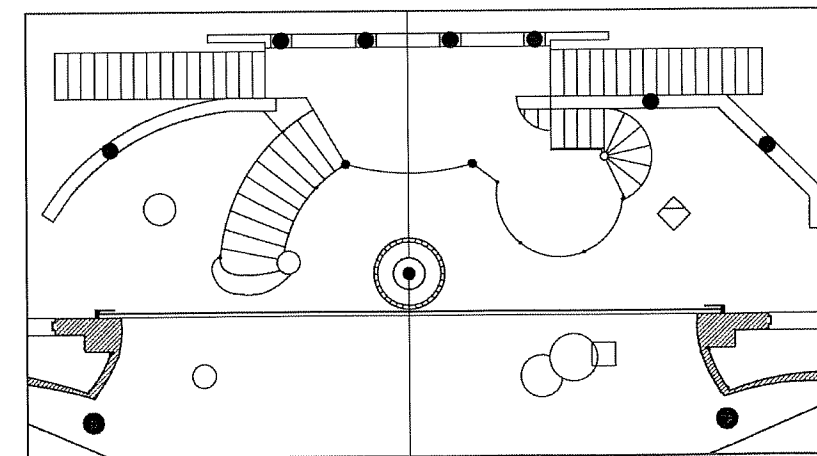

4. BEN x UC

Scene II

nt is  
theatre  
must g  
e

when



*Much Ado About Nothing*

**BENEDICK**

I have almost matter enough in me for such an embassy; and I leave you.

*Exit*

**CLAUDIO**

My liege, your highness now may do me good.

**DON PEDRO**

My love is thine to teach: teach it but how,  
And thou shalt see how apt it is to learn  
Any hard lesson that may do thee good.

**CLAUDIO**

Hath Leonata any son, my lord?

**DON PEDRO**

No child but Hero; she's her only heir.

Dost thou affect her, Claudio?

**CLAUDIO**

O, my lord,

When you went onward on this ended action,

I look'd upon her with a soldier's eye, <sup>4</sup>

That liked, but had a rougher task in hand

Than to drive liking to the name of love:

But now I am return'd and that war-thoughts

Have left their places vacant, in their rooms

Come thronging soft and delicate desires, <sup>5</sup>

All prompting me how fair young Hero is,

Saying, I liked her ere I went to wars.

**DON PEDRO**

Thou wilt be like a lover presently

And tire the hearer with a book of words.

If thou dost love fair Hero, cherish it,

And I will break with her and with her mother,

And thou shalt have her. Was't not to this end

That thou began'st to twist so fine a story?

**CLAUDIO**

How sweetly you do minister to love,

That know love's grief by his complexion!

*Much Ado About Nothing*

1. URS ent. USR, hide

BOR ent USR, hide

OAT ent SL, hide

2. BEN ex USR

3. DP x DC

4. CLA slow circle

5. CLA x to DP

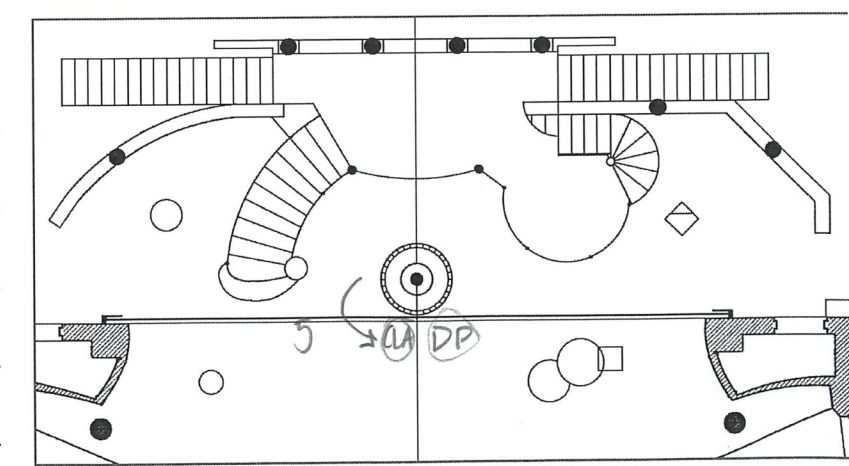
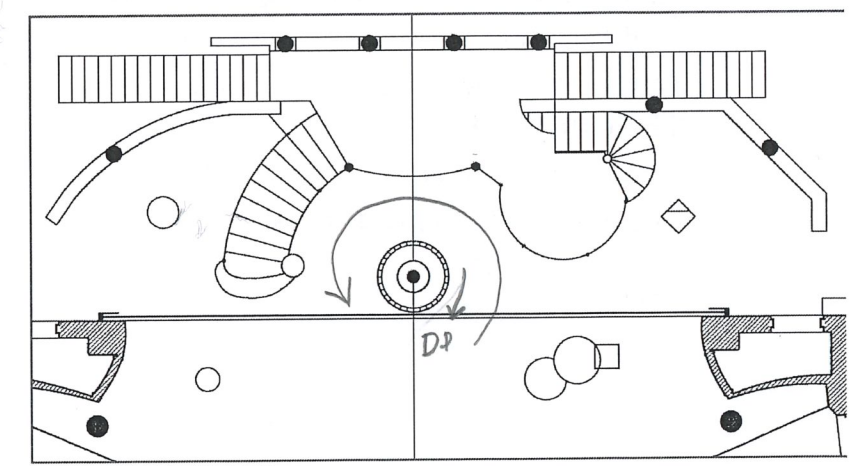
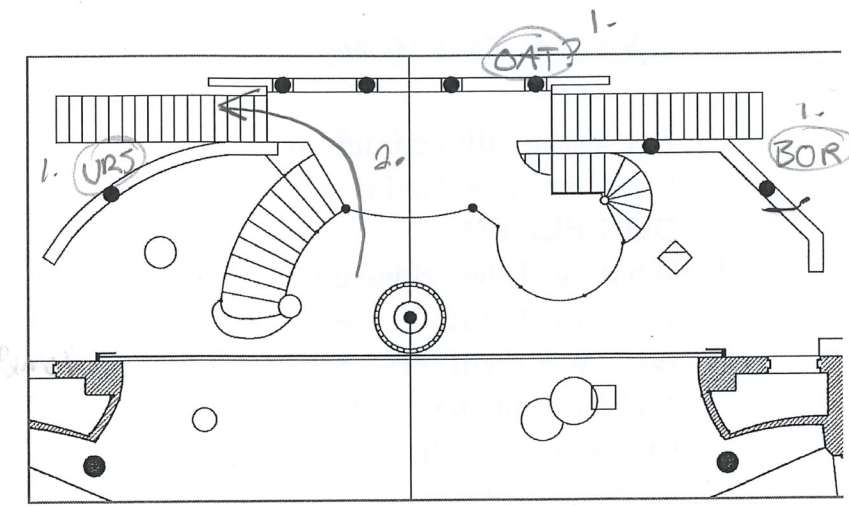



*Much Ado About Nothing*

But lest my liking might too sudden seem,  
I would have salved it with a longer treatise.

**DON PEDRO**

- ① What need the bridge much broader than the flood?  
The fairest grant is the necessity.
- ② Look, what will serve is fit: 'tis once, thou lovest,  
And I will fit thee with the remedy.  
I know we shall have revelling to-night:  
I will assume thy part in some disguise  
And tell fair Hero I am Claudio,  
And in her bosom I'll unclasp my heart  
And take her hearing prisoner with the force  
And strong encounter of my amorous tale:  
Then after to her mother will I break;  
And the conclusion is, she shall be thine. *LED out*
- ③ In practise let us put it presently.

*Exeunt*

*Much Ado About Nothing*

*CLA ex SR*

2. *DP: CLA x UC*

3. *DP: CLA ex USR*

*UC ex SR*  
*BOR ex USR*

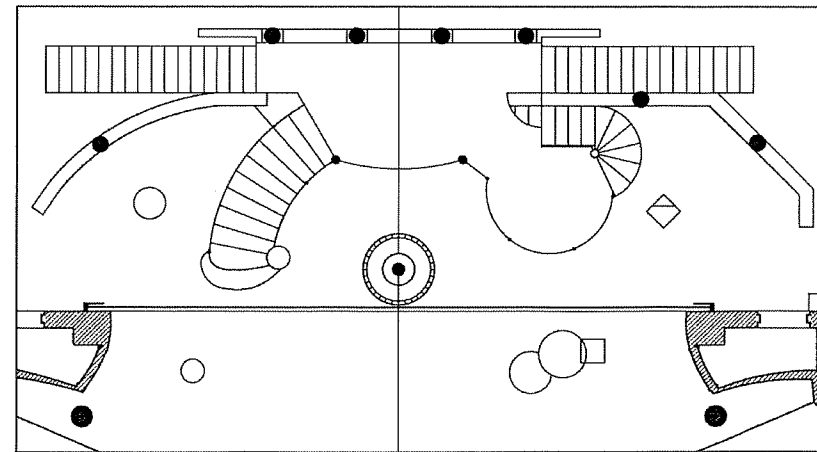
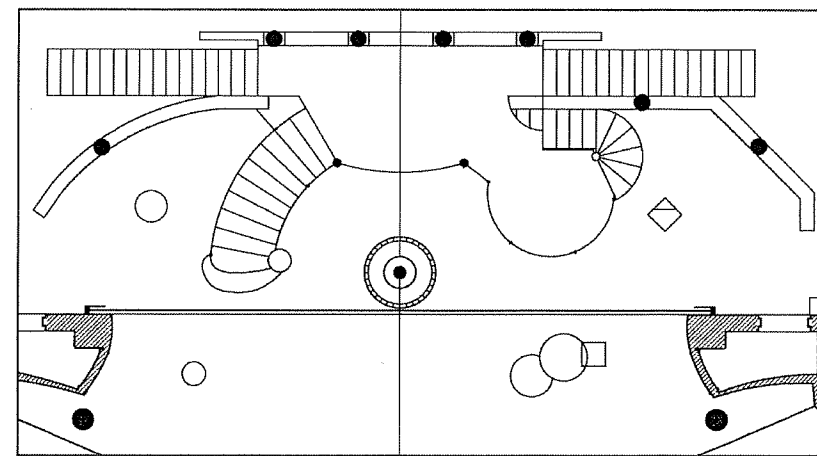
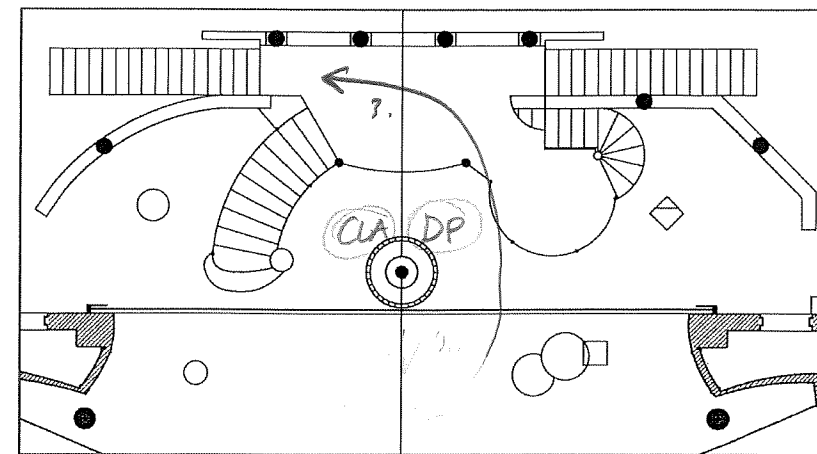

Scene II

*Much Ado About Nothing*

ACT I, SCENE II.

1. A room in LEONATA's house.

LEONATA

2. How now, sister!

ANTONIA

Sister, I can tell you strange news that you yet dreamt not of.

LEONATA

Are they good? 3.

ANTONIA

As the event stamps them: but they have a good cover; they show well outward. The prince and Count Claudio, walking in mine orchard, were thus much overheard by a man of mine: the prince discovered to Claudio that he loved my niece your daughter and meant to acknowledge it this night in a dance: and if he found her accordant, he meant to take the present time by the top and instantly break with you of it.

LEONATA

Hath the fellow any wit that told you this?

ANTONIA

A good sharp fellow: I will send for him; and question him yourself.

LEONATA

No, no; we will hold it as a dream till it appear itself: but I will acquaint my daughter withal, that she may be the better prepared for an answer, if peradventure this be true. Go you and tell her of it. 4. 5.

*Enter Attendants*

Cousins, you know what you have to do. O, I cry you mercy, friend; go you with me, and I will use your skill. Good cousin, have a care this busy time.

*Exeunt*

*Much Ado About Nothing*

1. LEO ent SR esc to buldge, w/ clipboard

2. ANT ent DSR, x to pool  
Yvone Skippie

3. LEO x US, ↓ SL, meet ANT

4. LEO guide ANT to pool

5. ANT ex USR, LEO same

6. ex together

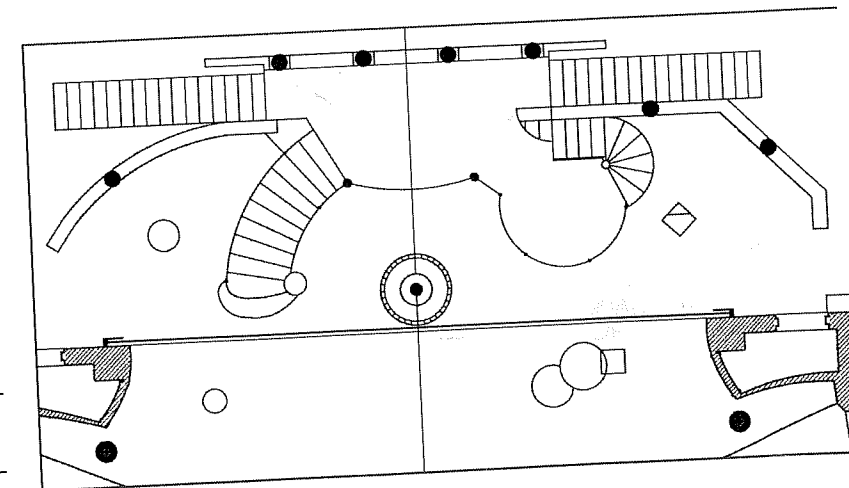
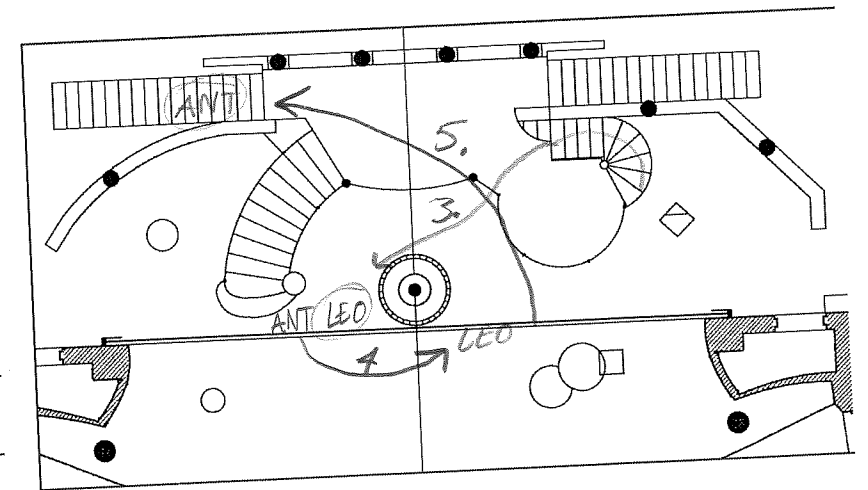
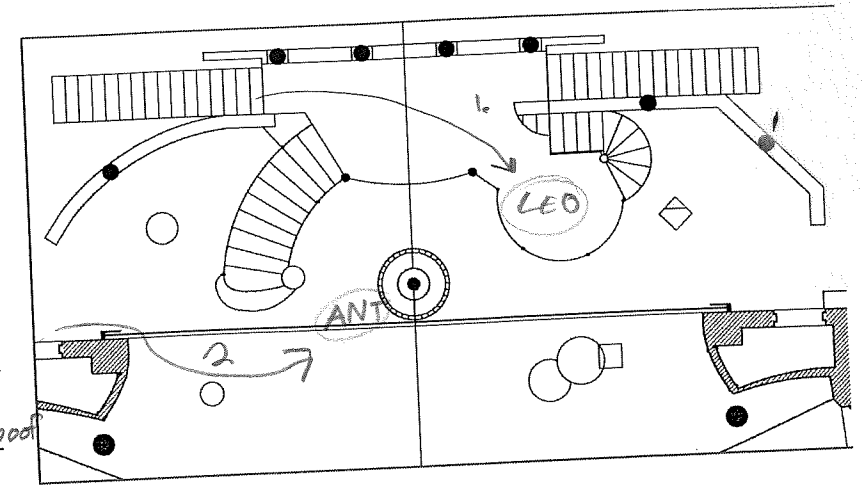

Scene II



Much Ado About Nothing

ACT I, SCENE III.

The same.

1,2 CONRADE

What the good-year, my lord! why are you thus out of measure sad?

DON JOHN

There is no measure in the occasion that breeds; therefore the sadness is without limit.

CONRADE

You should hear reason.

DON JOHN

And when I have heard it, what blessing brings it?

CONRADE

If not a present remedy, at least a patient sufferance.

DON JOHN

I wonder that thou, being, as thou sayest thou art, born under Saturn, goest about to apply a moral medicine to a mortifying mischief. I cannot hide what I am: I must be sad when I have cause and smile at no man's jests, eat when I have stomach and wait for no man's leisure, sleep when I am drowsy and tend on no man's business, laugh when I am merry and claw no man in his humour.

CONRADE

Yea, but you must not make the full show of this till you may do it without controlment. You have of late stood out against your brother, and he hath ta'en you newly into his grace; where it is impossible you should take true root but by the fair weather that you make yourself: it is needful that you frame the season for your own harvest.

DON JOHN

3. I had rather be a canker in a hedge than a rose in his grace, and it better fits my blood to be disdained of all than to fashion a carriage to rob love from any: in this, though I cannot be said to be a flattering honest man, it must not be denied but I am a plain-dealing villain. I am trusted with a muzzle and enfranchised with a clog; therefore I have decreed not to sing in my cage. If I had my mouth, I would bite; if I had my liberty, I would do my liking: in the meantime let me be that I am and seek not to alter me. 4.

CONRADE

5. Can you make no use of your discontent?

DON JOHN

6. I make all use of it, for I use it only. Who comes here?

7.

Much Ado About Nothing

1. DJ ent DSL, DS of Fountain, sit on lower step

2. CON ent DSL, i Fountain, x e sit on poof

3. DJ i Fountain

4. DJ i poof, land UC under platform

5. CON stand, turn to face DJ

6. DJ x to CON, back him up to Fount. lower step, sit

7. BOR whistle (other noise), slowly ent USR

DJ: swiss army knife, apple

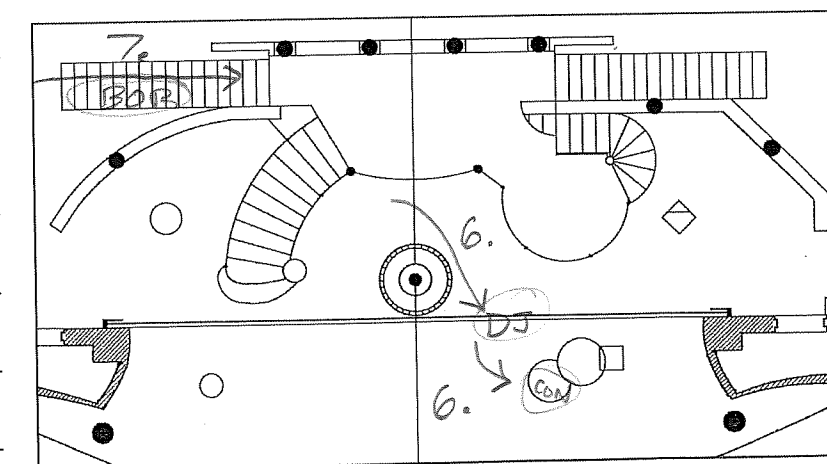
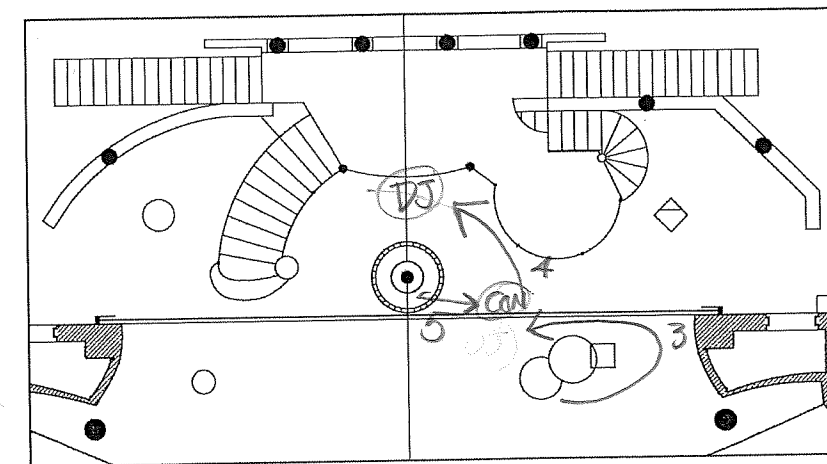
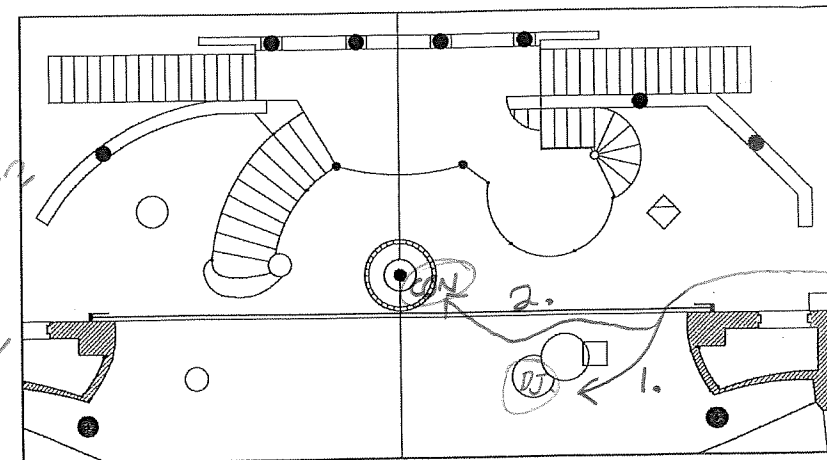

Scene III



*Much Ado About Nothing*

1. Enter BORACHIO

What news, Borachio?

**BORACHIO**

I came yonder from a great supper: the prince your brother is royally entertained by Leonata: and I can give you intelligence of an intended marriage.

**DON JOHN**

Will it serve for any model to build mischief on? What is he for a fool that betroths himself to unquietness?

**BORACHIO**

Marry, it is your brother's right hand.

**DON JOHN**

Who? the most exquisite Claudio?

**BORACHIO**

Even he.

**DON JOHN**

A proper squire! And who, and who? which way looks he?

**BORACHIO**

Marry, on Hero, the daughter and heir of Leonata.

**DON JOHN**

2. A very forward March-chick! How came you to this?

**BORACHIO**

As I was smoking in a quiet room, comes me the prince and Claudio, hand in hand in sad conference: I whipt me behind the arras; and there heard it agreed upon that the prince should woo Hero for himself, and having obtained her, give her to Count Claudio.

**DON JOHN**

5. Come, come, let us thither: this may prove food to my displeasure. That young start-up hath all the glory of my overthrow: if I can cross him any way, I bless myself every way. You are both sure, and will assist me?

**CONRADE**

To the death, my lord.

**DON JOHN**

Let us to the great supper: their cheer is the greater that I am subdued. Would the cook were of my mind! Shall we go prove what's to be done?

**BORACHIO**

7. We'll wait upon your lordship. / next

*Much Ado About Nothing*

1. BOR x DSR (Burps)\*

2. DJ x to BOR, slow

3. DJ slip BOR money

4. BOR "whip" around DSR

statue

5. DJ call BOR: CON

to him

6. DJ step US, turn

back to look @ BOR: CON

7. BOR: CON salute DJ

all ex USR

funneey

DJ does not look at BOR

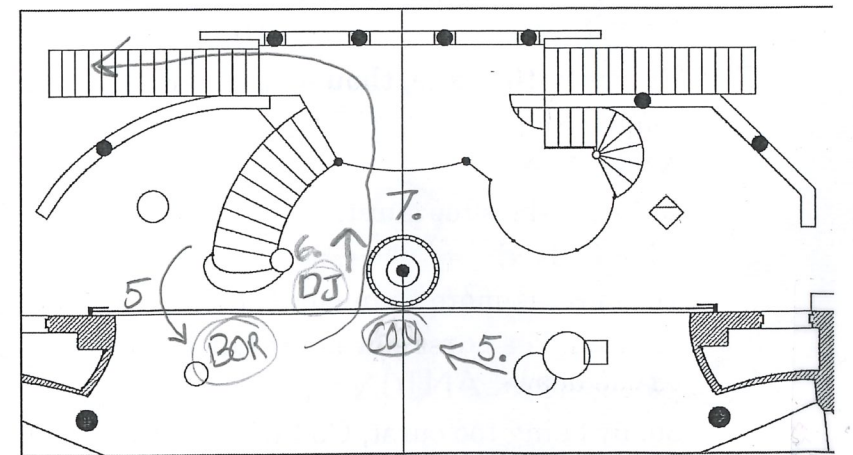
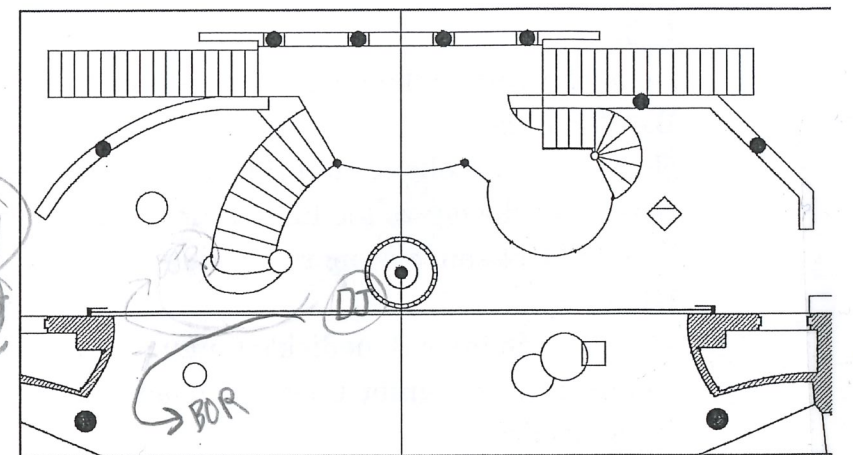
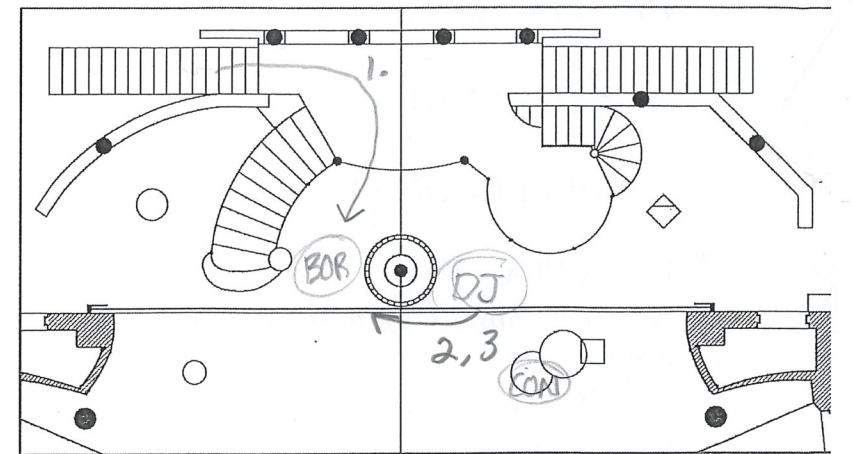

BOR: Flask DJ: paper money



*Much Ado About Nothing*

ACT II, SCENE I.

A hall in LEONATA'S house.

**LEONATA**  
Was not Count John here at supper?

**ANTONIA**  
I saw him not.

**BEATRICE**  
How tartly that gentleman looks! I never can see him but I am heart-burned an hour after.

**HERO**  
He is of a very melancholy disposition.

**BEATRICE**  
He were an excellent man that were made just in the midway between him and Benedick: the one is too like an image and says nothing, and the other too like my lady's eldest son, evermore tattling.

**HERO**  
Then half Signior Benedick's tongue in Count John's mouth, and half Count John's melancholy in Signior Benedick's face,--

**BEATRICE**  
3. With a good leg and a good foot, madam, and money enough in his purse, such a man would win any woman in the world, if a' could get her good-will.

**LEONATA**  
By my troth, niece, thou wilt never get thee a husband, if thou be so shrewd of thy tongue. 4.

**ANTONIA**  
In faith, she's too curst.

**BEATRICE**  
Too curst is more than curst: I shall lessen God's sending that way; for it is said, 'God sends a curst cow short horns;' but to a cow too curst he sends none.

**LEONATA**  
So, by being too curst, God will send you no horns.

**BEATRICE**  
5. Just, if he send me no husband; for the which blessing I am at him upon my knees every morning and evening. Lord, I could not endure a husband with a beard on his face: I had rather lie in the woollen.

**LEONATA**  
You may light on a husband that hath no beard.

Act II

*Much Ado About Nothing*

1. LEO, ANT, BEA, HO, MAR, URS  
ent SR esc

LEO/ANT espresso/saucers

MAR/URS liquor glasses

2. BEA x to HO

3. BEA in HO, to CS on plat

4. ANT/LEO set cups on statue,  
x to SR

5. BEA x to buldge, wander  
about plat,

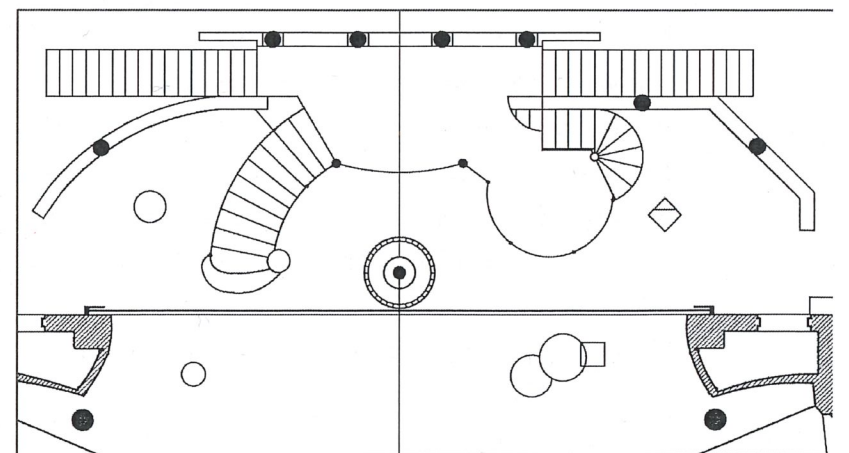
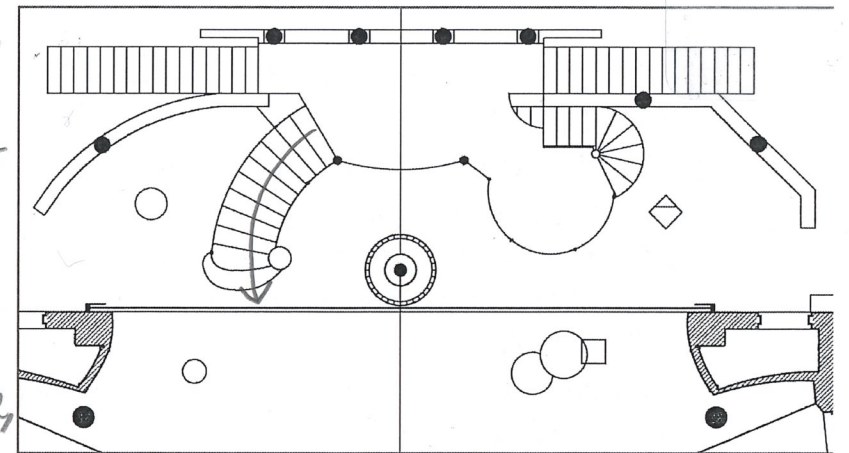
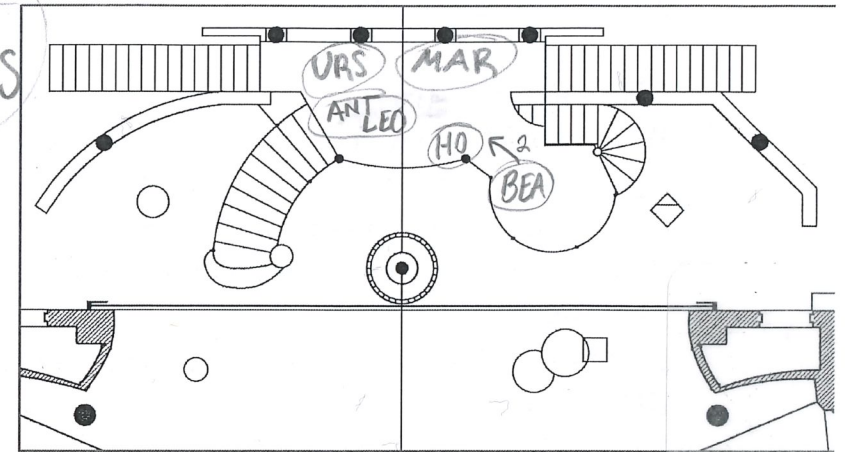

Scene I



Much Ado About Nothing

BEATRICE

1. What should I do with him? dress him in my apparel and make him my waiting-gentlewoman? He that hath a beard is more than a youth, and he that hath no beard is less than a man: and he that is more than a youth is not for me, and he that is less than a man, I am not for him.

ANTONIA

[To HERO] Well, niece, I trust you will be ruled by your mother.

BEATRICE

Yes, faith; it is my cousin's duty to make curtsy and say 'Mother, as it please you.' But yet for all that, cousin, let him be a handsome fellow, or else make another curtsy and say 'Mother, as it please me.'

LEONATA

Well, niece, I hope to see you one day fitted with a husband.

BEATRICE

3. Not till God make men of some other metal than earth. Would it not grieve a woman to be overmastered with a piece of valiant dust? to make an account of her life to a clod of wayward dirt? No, aunt, I'll none: Adam's sons are my brethren; and, truly, I hold it a sin to match in my kindred. 4.

LEONATA

Daughter, remember what I told you: if the prince do solicit you in that kind, you know your answer.

BEATRICE

6. The fault will be in the music, cousin, if you be not wooed in good time: if the prince be too important, tell him there is measure in every thing and so dance out the answer. For, hear me, Hero: wooing, wedding, and repenting, is as a Scotch jig, a measure, and a [cinque pace]: the first suit is hot and hasty, like a Scotch jig, and

7. full as fantastical; the wedding, mannerly-modest, as a measure, full of state and ancientry; and then comes repentance and, with his bad legs, falls into the [cinque pace] faster and faster, till he sink into his grave. 5.

LEONATA

Cousin, you apprehend passing shrewdly.

BEATRICE

I have a good eye, madam; I can see a church by daylight.

LEONATA

8. The revellers are entering, sister: make good room. 9.

All put on their masks

Much Ado About Nothing

1. LEO x DSL to fount, sit  
ANT x CS to poof, sit

2. HO x ↓ SR ANT look

3. BEA HO x ↓ SR

4. MAR/URS ex SR esc, take cups, saucers, glasses

5. HO x to fount.

6. BEA slow x to HO

7. BEA x to poof, sit

8. MAR/URS ent USR w/ masks

9. DP, DJ, BEN, CLA, BAL, BOR, CON ent DSR, masked

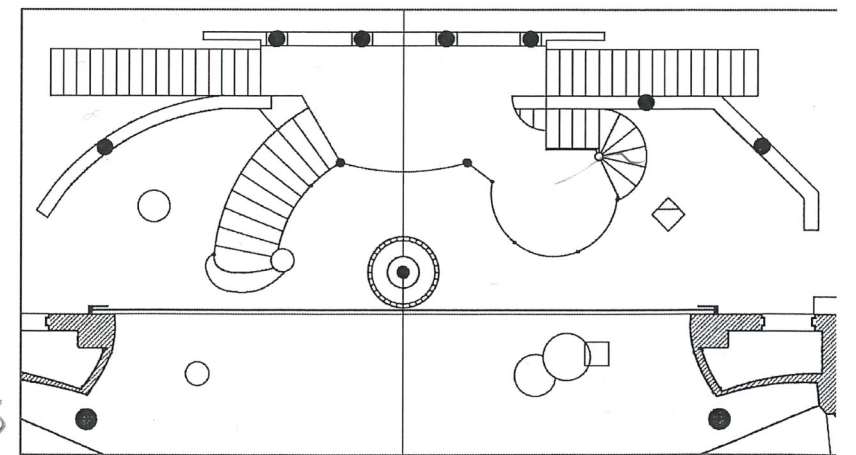
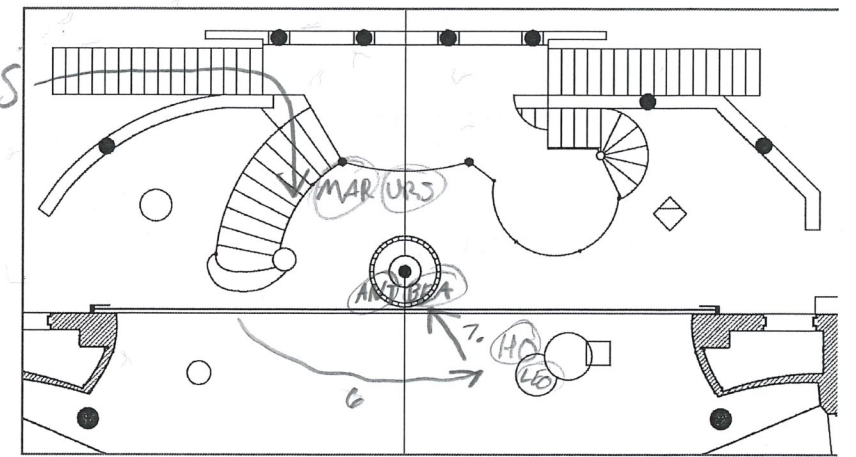
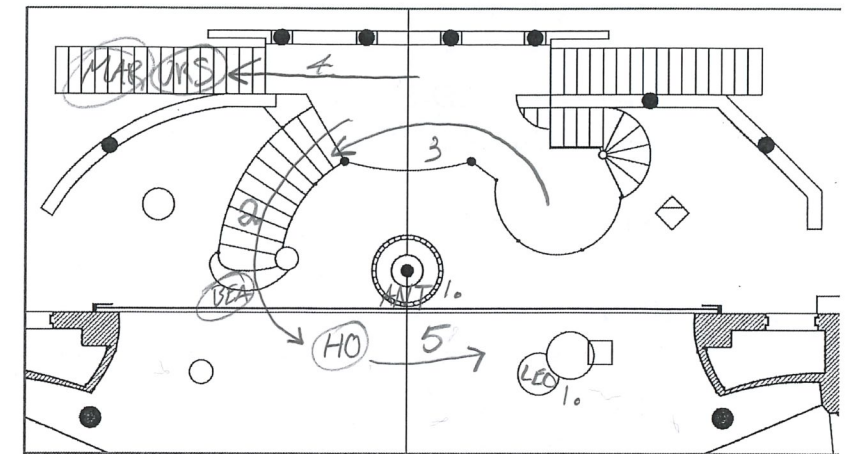

Scene II

Lily - sophia/sjd  
Meg - brooke/Russo



Much Ado About Nothing

Enter DON PEDRO, CLAUDIO, BENEDICK, BALTHASAR, DON JOHN, BORACHIO, MARGARET, URSULA and others, masked

1. DON PEDRO

Lady, will you walk about with your friend?

HERO

So you walk softly and look sweetly and say nothing, I am yours for the walk; and especially when I walk away.

DON PEDRO

With me in your company?

HERO

I may say so, when I please.

DON PEDRO

And when please you to say so?

HERO

When I like your favour; for God defend the lute should be like the case!

DON PEDRO

Speak low, if you speak love.

Drawing her aside

BORACHIO

3. Well, I would you did like me.

MARGARET

So would not I, for your own sake; for I have many ill-qualities.

BORACHIO

Which is one?

MARGARET

I say my prayers aloud.

BORACHIO

I love you the better: the hearers may cry, Amen.

MARGARET

God match me with a good dancer!

BORACHIO

Amen.

MARGARET

And God keep him out of my sight when the dance is done! Answer, clerk.

BORACHIO

No more words: the clerk is answered.

Much Ado About Nothing

Dance w/ couples, rotate clockwise

Boys + ANT on left side

1. Start, turning first rotation

(a) top of music

2. DP/HO DC, still dancing

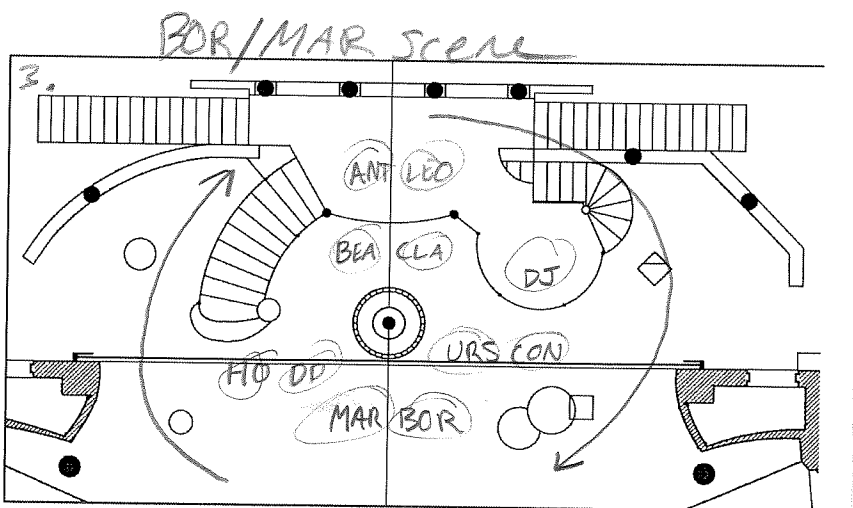
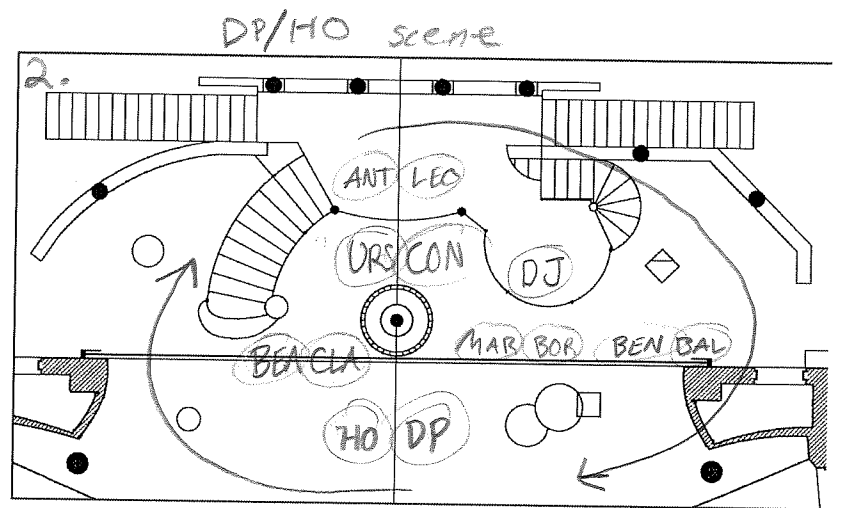
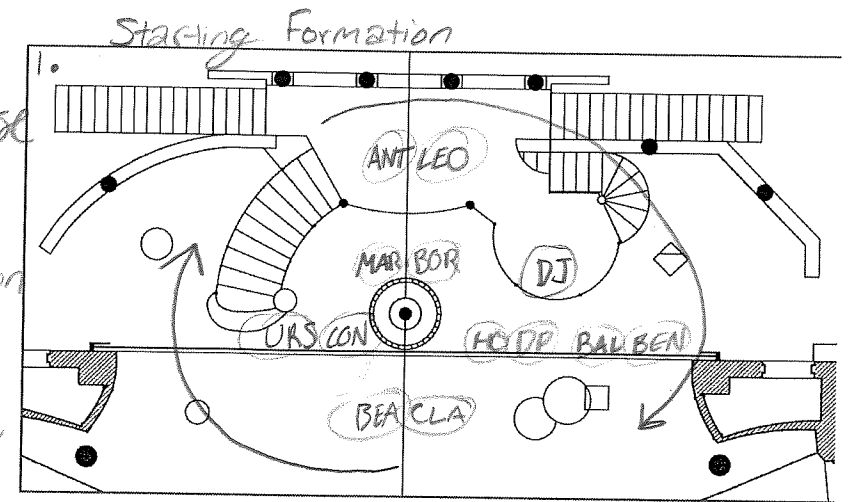

3. BOR/MAR DC, still dance

Scene II



Much Ado About Nothing

1. CONRADE

White-handed mistress, one sweet word with thee.

2. URSULA

Honey, and milk, and sugar: there is three.

CONRADE

Nay then two treys, and if you grow so nice.

Oranges, dates, and sherry: well run, dice!

There's half a dozen sweets.

URSULA

Seventh sweet, adieu.

You talk too smooth, I'll play no more with you.

CONRADE

One word in secret.

URSULA

Let it not be sweet.

3.

BEATRICE

Will you not tell me who told you so?

BENEDICK

No, you shall pardon me.

BEATRICE

Nor will you not tell me who you are?

BENEDICK

Not now.

BEATRICE

That I was disdainful, and that I had my good wit out of the 'Hundred Merry

Tales:'--well this was Signior Benedick that said so.

BENEDICK

What's he?

BEATRICE

I am sure you know him well enough.

BENEDICK

Not I, believe me.

BEATRICE

Did he never make you laugh?

BENEDICK

I pray you, what is he?

BEATRICE

Why, he is the prince's jester: a very dull fool; only his gift is in devising impossible

4.

Much Ado About Nothing

1. During ↑ ↓, BEN swap w/ CLA, before CON line

2. ANT x ↓ SR  
LEO x ↓ SL

3. Final Form, DJ x ↓ SL

4. When Dance ends, Mingle formation,

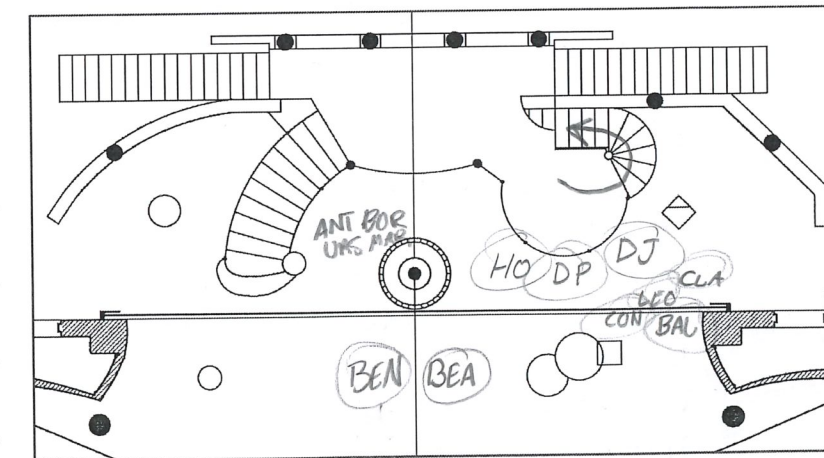
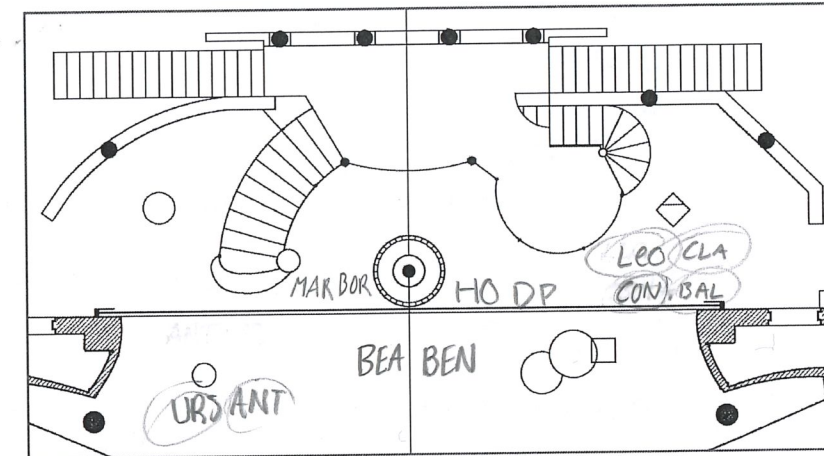
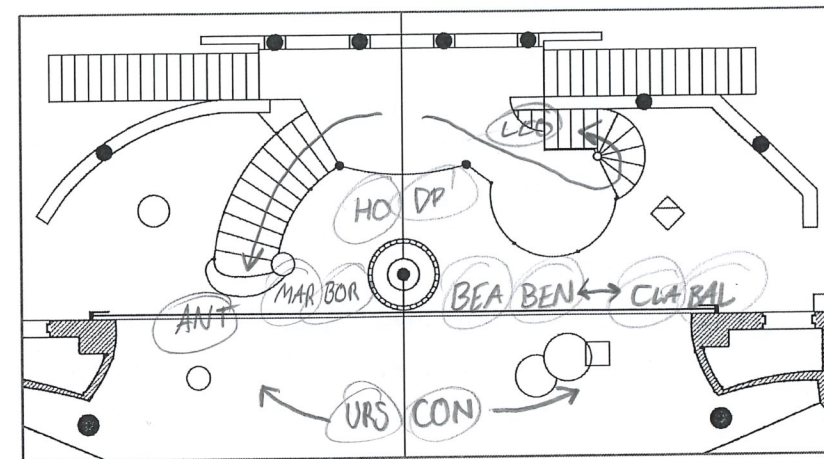

Scene II



Much Ado About Nothing

but in his villany; for he both pleases men and angers them, and then they laugh at him and beat him. I am sure he is in the fleet: I would he had boarded me.

**BENEDICK**

When I know the gentleman, I'll tell him what you say.

**BEATRICE**

Do, do: he'll but break a comparison or two on me; which, peradventure not marked or not laughed at, strikes him into melancholy; and then there's a partridge wing saved, for the fool will eat no supper that night.

Music

We must follow the leaders. ①.

**BENEDICK**

In every good thing.

**BEATRICE**

Nay, if they lead to any ill, I will leave them at the next turning. ②.

*Dance. Then exeunt all except DON JOHN, BORACHIO, and CLAUDIO*

**DON JOHN**

Sure my brother is amorous on Hero and hath withdrawn her mother to break with her about it. The ladies follow her and but one visor remains.

**BORACHIO**

And that is Claudio: I know him by his bearing. ③.

**DON JOHN**

Are not you Signior Benedick?

**CLAUDIO**

You know me well; I am he.

**DON JOHN**

Signior, you are very near my brother in his love: he is enamoured on Hero; I pray you, dissuade him from her: she is no equal for his birth: you may do the part of an honest man in it.

**CLAUDIO**

How know you he loves her?

**DON JOHN**

I heard him swear his affection.

**BORACHIO**

So did I too; and he swore he would marry her to-night.

Much Ado About Nothing

1. Conga Line! ex USR  
all ex EXCEPT DJ, BOR, CLA

2. CLA X to Fount, sit

3. DJ W of proof, to CLA  
BOR n of proof, to CLA

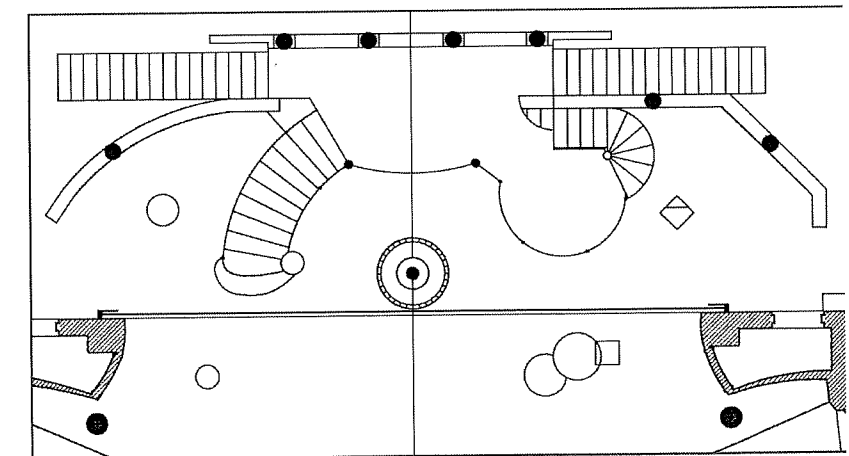
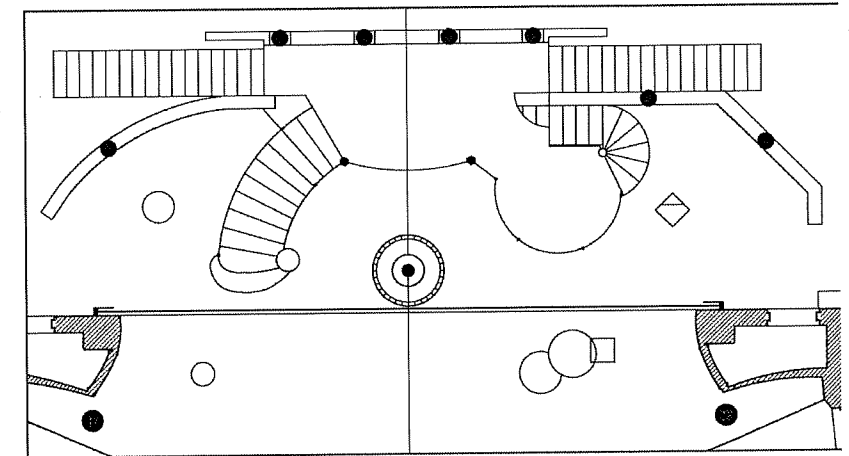
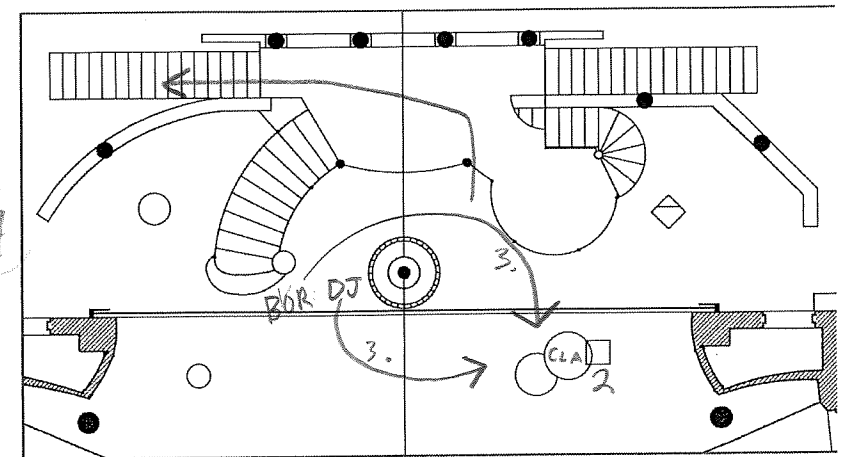

Scene II

*Much Ado About Nothing*

**DON JOHN**

Come, let us to the banquet.

1. *Exeunt DON JOHN and BORACHIO*

**CLAUDIO**

Thus answer I in the name of Benedick,  
But hear these ill news with the ears of Claudio.  
'Tis certain so; the prince woos for himself.  
Friendship is constant in all other things  
Save in the office and affairs of love:  
Therefore, all hearts in love use their own tongues;  
Let every eye negotiate for itself  
And trust no agent; for beauty is a witch  
Against whose charms faith melteth into blood.  
This is an accident of hourly proof, 2.  
Which I mistrusted not. Farewell, therefore, Hero!

*Re-enter BENEDICK*

**BENEDICK**

Count Claudio?

**CLAUDIO**

Yea, the same.

**BENEDICK**

Come, will you go with me?

**CLAUDIO**

Whither?

**BENEDICK**

Even to the next willow, about your own business, county, for the prince hath got your Hero.

**CLAUDIO**

I wish him joy of her.

**BENEDICK**

But did you think the prince would have served you thus?

**CLAUDIO**

I pray you, leave me.

II 43A

*Much Ado About Nothing*

1. DJ/BOR x UR, ex USR

2. BEN ent USR, x to fount

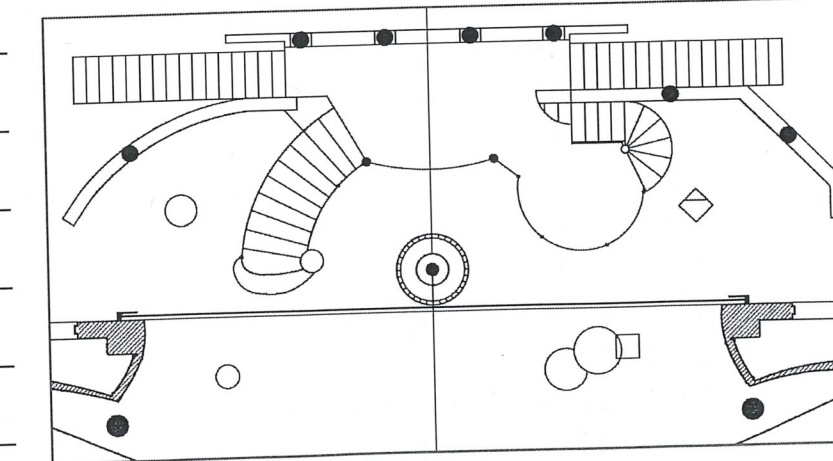
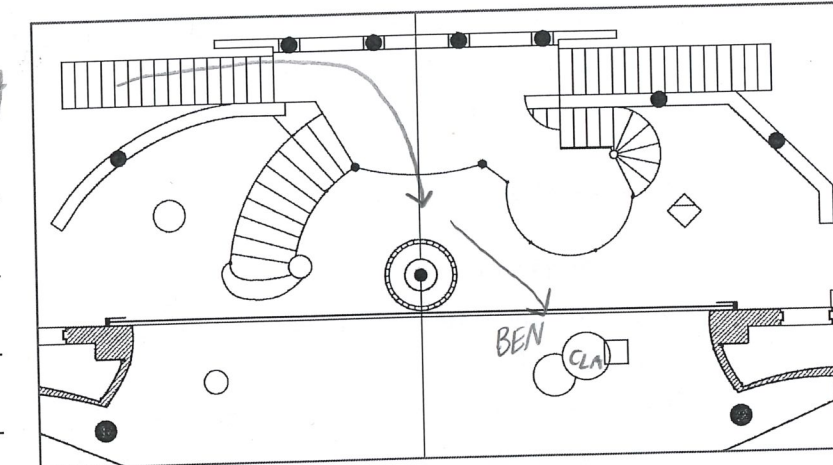
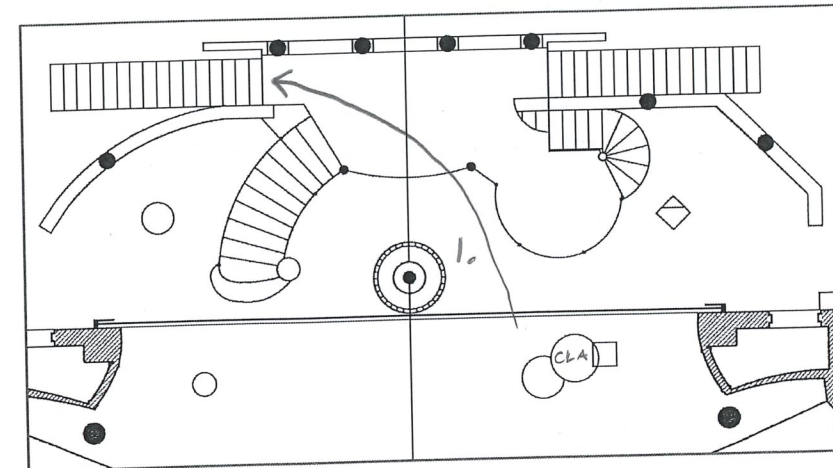

Scene II



Much Ado About Nothing

**BENEDICK**

Ho! now you strike like the blind man: 'twas the boy that stole your meat, and you'll beat the post.

**CLAUDIO**

If it will not be, I'll leave you. 1.

Exit

**BENEDICK**

Alas, poor hurt fowl! now will he creep into the reeds. But that my Lady Beatrice should know me, and not know me! The prince's fool! Ha? It may be I go under that title because I am merry. Yea, but so I am apt to do myself wrong; I am not so reputed: it is the base, though bitter, disposition of Beatrice that puts the world into her person and so gives me out. Well, I'll be revenged as I may. 2.

Re-enter DON PEDRO

**DON PEDRO**

3. Now, signior, where's the count? did you see him?

**BENEDICK**

Troth, my lord, I have played the part of Lady Fame. I found him here as melancholy as a [lodge in a warren]: I told him, and I think I told him true, that your grace had got the good will of this young lady; and I offered him my company to a willow-tree to bind him up a rod, as being worthy to be whipped.

**DON PEDRO**

To be whipped! What's his fault?

**BENEDICK**

The flat transgression of a schoolboy, who, being overjoyed with finding a birds' nest, shows it his companion, and he steals it.

**DON PEDRO**

Wilt thou make a trust a transgression? The transgression is in the stealer.

**BENEDICK**

Yet it had not been amiss the rod had been made, and the willow garland, too; for the garland he might have worn himself, and the rod he might have bestowed on you, who, as I take it, have stolen his birds' nest.

**DON PEDRO**

I will but teach them to sing, and restore them to the owner.

**BENEDICK**

... my faith you say honestly.

Much Ado About Nothing

1. CLA ex DSL

2. DP ent USR, X DSL

3. BEN false ex DSR, turn around

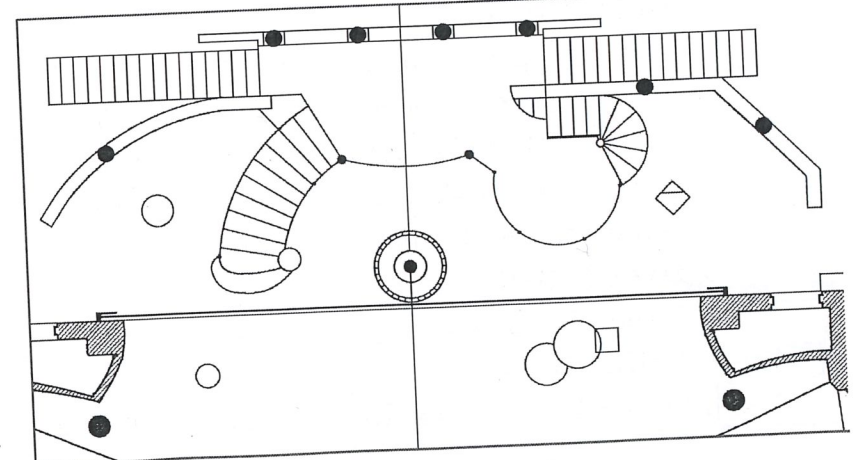
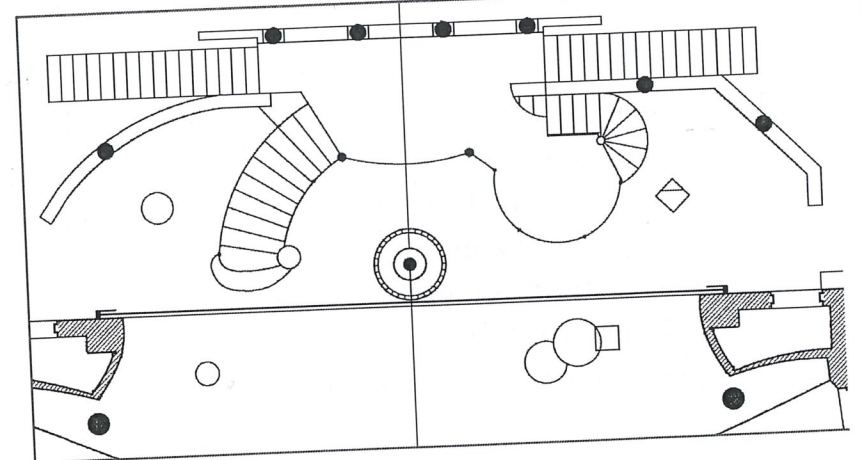
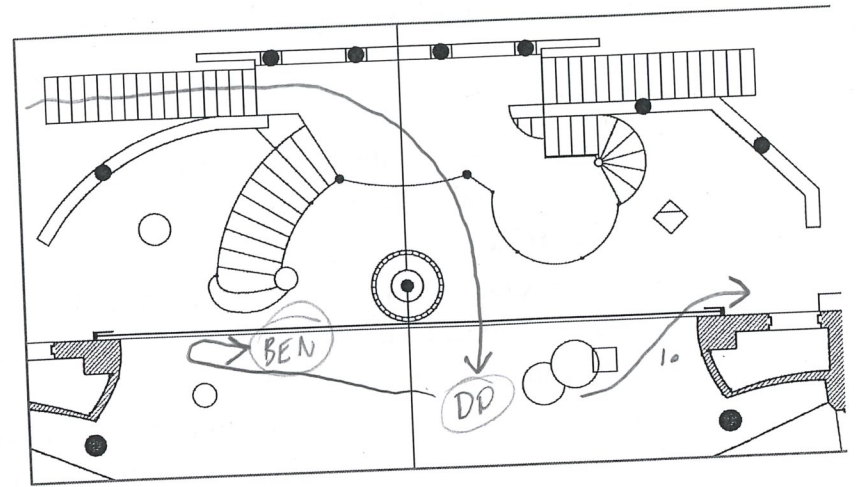

Scene II



Much Ado About Nothing

DON PEDRO

1. The Lady Beatrice hath a quarrel to you: the gentleman that danced with her told her she is much wronged by you.

BENEDICK

2. O, she misused me past the endurance of a block! an oak but with one green leaf on it would have answered her; my very visor began to assume life and scold with her. She told me, not thinking I had been myself, that I was the prince's jester, that I was duller than a great thaw; huddling jest upon jest with such impossible conveyance upon me that I stood like a man at a mark, with a whole army shooting at me. She speaks daggers, and every word stabs: if her breath were as terrible as 3. her terminations, there were no living near her; she would infect to the north star. I would not marry her, though she were endowed with all that Adam had left him before he transgressed: she would have made Hercules have turned spit, yea, and have cleft his club to make the fire too. Come, talk not of her: you shall find her an infernal Gorgon in good apparel. I would to God some scholar would conjure her; for certainly, while she is here, a man may live as quiet in hell as in a sanctuary; and people sin upon purpose, because they would go thither; so, indeed, all disquiet, horror and perturbation follows her.

DON PEDRO

Look, here she comes. 5, 9

Enter CLAUDIO, BEATRICE, HERO, and LEONATA

BENEDICK

Will your grace command me any service to the world's end? I will go on the slightest errand now to the Antipodes that you can devise to send me on; I will fetch you a tooth-picker now from the furthest inch of Asia, fetch you a hair off the great Cham's beard, do you any embassy to the Pigmies, rather than hold three words' conference with this harpy. You have no employment for me? 6

DON PEDRO

7. None, but to desire your good company.

BENEDICK

9. O God, sir, here's a dish I love not: I cannot endure my Lady Tongue. 8, 10

Exit

DON PEDRO

Come, lady, come; you have lost the heart of Signior Benedick.

Much Ado About Nothing

1. DP x to fount, sit

2. BEN x DC

3. BEN n fount, sit fount

4. BEN stand, U fount, x to DC

5. BEN x to DP

6. BEN x DSL, x n roof, x DSR

7. DP x DSR

8. BEN salute, ex DSR

9. BEA : CLA ent USL, BEA pulling CLA by the ear, x DC

10. HO : LEO ent SR esc

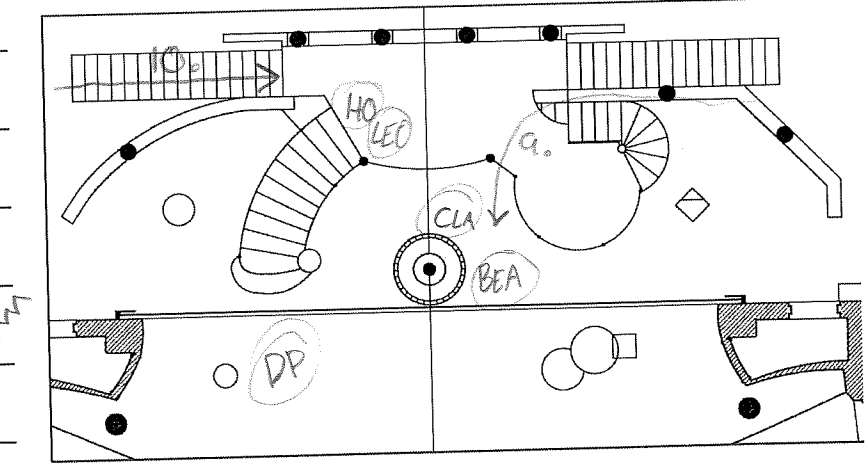
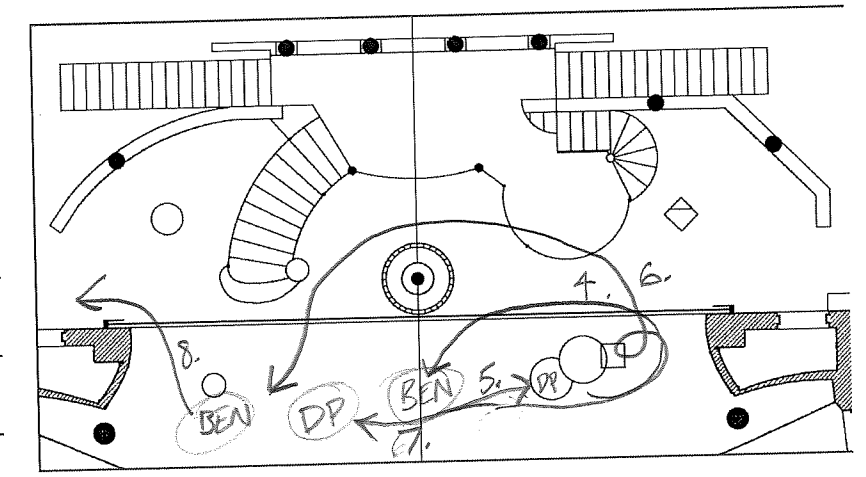
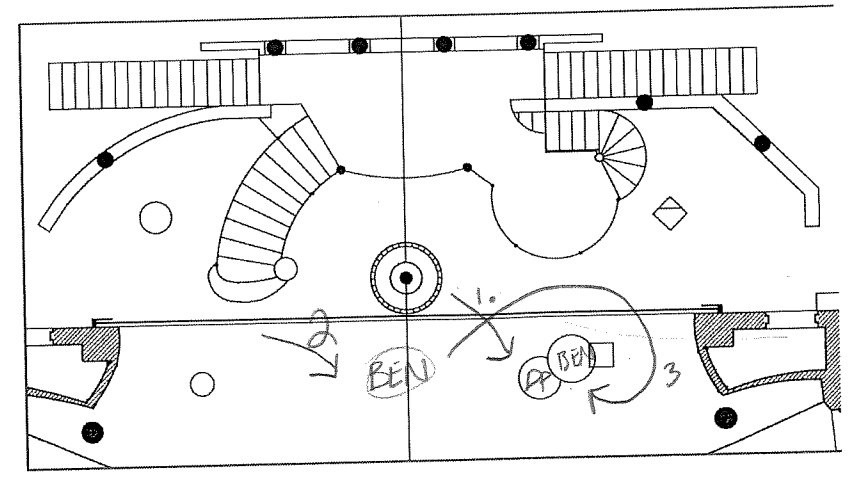

Scene II



*Much Ado About Nothing*

**BEATRICE**

1. Indeed, my lord, he lent it me awhile; and I gave him use for it, a double heart for his single one: marry, once before he won it of me with false dice, therefore your grace may well say I have lost it.

**DON PEDRO**

You have put him down, lady, you have put him down.

**BEATRICE**

So I would not he should do me, my lord, lest I should prove the mother of fools. I have brought Count Claudio, whom you sent me to seek.

**DON PEDRO**

Why, how now, count! wherefore are you sad?

**CLAUDIO**

Not sad, my lord.

**DON PEDRO**

How then? sick?

**CLAUDIO**

Neither, my lord.

**BEATRICE**

The count is neither sad, nor sick, nor merry, nor well; but civil count, civil as [an orange], and something of that jealous complexion.

**DON PEDRO**

I' faith, lady, I think your blazon to be true; though, I'll be sworn, if he be so, his conceit is false. Here, Claudio, I have wooed in thy name, and fair Hero is won: I have broke with her mother, and her good will obtained: name the day of marriage, and God give thee joy!

**LEONATA**

Count, take of me my daughter, and with her my fortunes: his grace hath made the match, and all grace say Amen to it.

**BEATRICE**

4. Speak, count, 'tis your cue.

**CLAUDIO**

Silence is the perfectest herald of joy: I were but little happy, if I could say how much. Lady, as you are mine, I am yours: I give away myself for you and dote upon the exchange.

**BEATRICE**

Speak, cousin; or, if you cannot, stop his mouth with a kiss, and let not him speak neither. 5, 6

**DON PEDRO**

In faith, lady, you have a merry heart.

*Much Ado About Nothing*

1. BEA x DSL to DC

2. BEA x USL, grab CLA by ear, take DSL

3. LEO: HO x ↓ stairs, LEO stop 1/2 ↓, HO cont. x DC to CLA

4. BEA shove CLA to HO

5. BEA in CLA/HO

6. HO whisper in CLA ear, x DSL

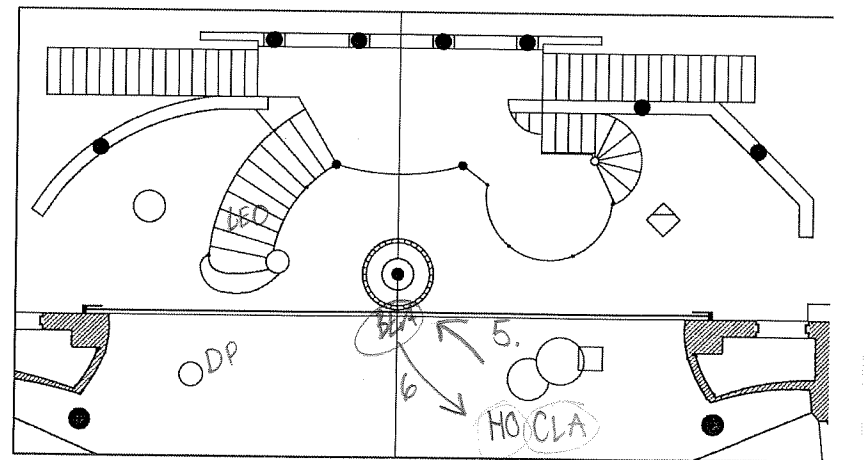
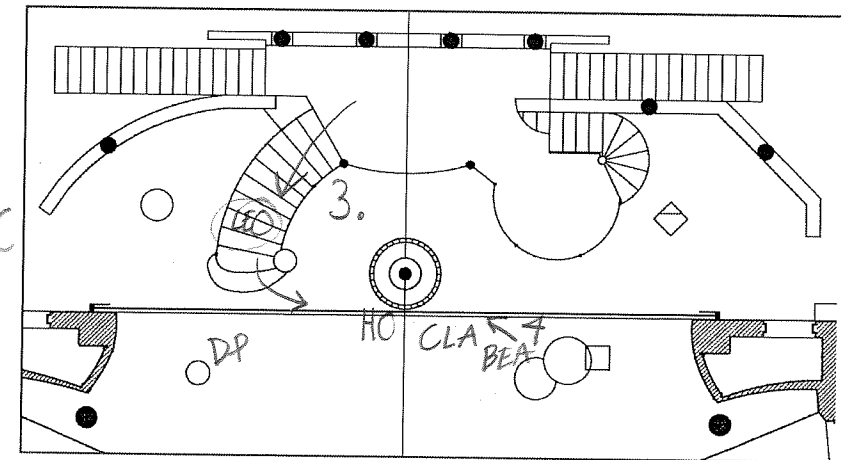
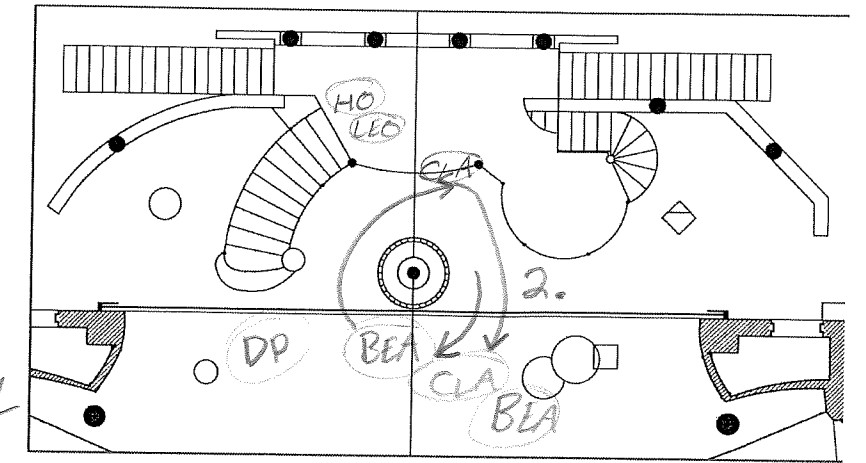

Scene II



Much Ado About Nothing

BEATRICE

Yea, my lord; I thank it, poor fool, it keeps on the windy side of care. My cousin tells him in his ear that he is in her heart.

HERO

And so I do, cousin.

BEATRICE

Good Lord, for alliance! Thus goes every one to the world but I; I may sit in a corner (1.) and cry heigh-ho for a husband!

DON PEDRO

Lady Beatrice, I will get you one. (2.)

BEATRICE

I would rather have one of your father's getting. Hath your grace ne'er a brother like you? Your father got excellent husbands, if a maid could come by them.

DON PEDRO

Will you have me, lady?

BEATRICE

(3.) No, my lord, unless I might have another for working-days: your grace is too costly to wear every day. But, I beseech your grace, pardon me: I was born to speak all mirth and no matter.

DON PEDRO

Your silence most offends me, and to be merry best becomes you; for, out of question, you were born in a merry hour.

BEATRICE

No, sure, my lord, my mother cried; but then there was a star danced, and under that was I born. Cousins, God give you joy!

LEONATA (4.)

Niece, will you look to those things I told you of?

BEATRICE

I cry you mercy, aunt. By your grace's pardon. (5.)

Exit

DON PEDRO

By my troth, a pleasant-spirited lady.

HERO

There's little of the melancholy element in her, my lord: she is never sad but when she sleeps.

LEONATA;

Much Ado About Nothing

- 1. BEA sit on poof
- 2. DP x UC to poof

- 3. BEA stand, uncomfortable, step back toward SL

- 4. LEO x ↓ SR

- 5. BEA ex UC

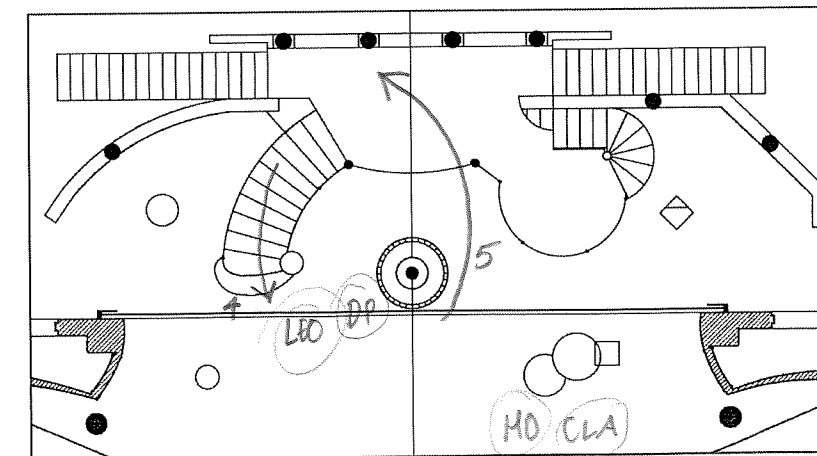
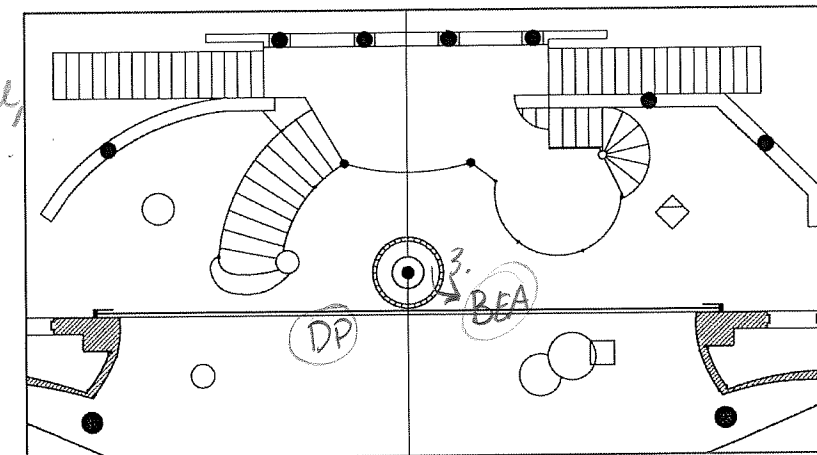
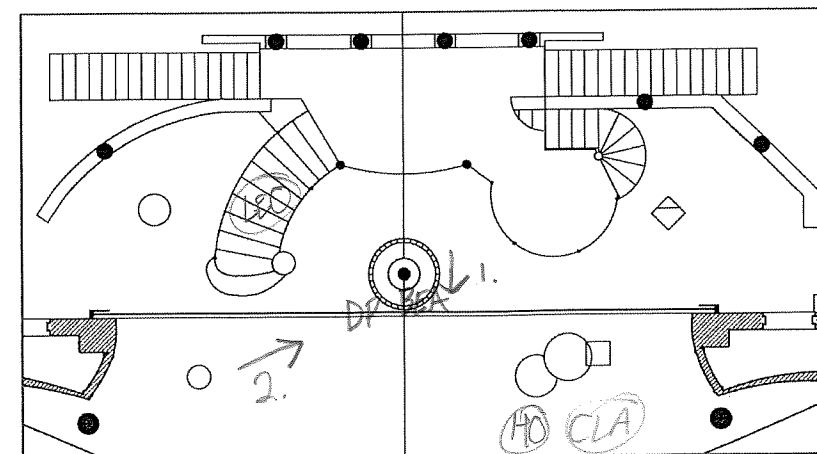

Scene II



Much Ado About Nothing

1. And not ever sad then; for I have heard my daughter say, she hath often dreamed of unhappiness and waked herself with laughing.

DON PEDRO

She cannot endure to hear tell of a husband.

HERO

O, by no means: she mocks all her wooers out of suit.

DON PEDRO

She were an excellent wife for Benedick.

LEONATA

2. O Lord, my lord, if they were but a week married, they would talk themselves mad.

DON PEDRO

County Claudio, when mean you to go to church?

CLAUDIO

To-morrow, my lord: time goes on crutches till love have all his rites.

LEONATA

Not till Monday, my dear son, which is hence a just seven-night; and a time too brief, too, to have all things answer my mind.

DON PEDRO

3. Come, you shake the head at so long a breathing: but, I warrant thee, Claudio, the time shall not go dully by us. I will in the interim undertake one of Hercules' labours; which is, to bring Signior Benedick and the Lady Beatrice into a mountain of affection the one with the other. I would fain have it a match, and I doubt not but to fashion it, if you three will but minister such assistance as I shall give you direction.

LEONATA

My lord, I am for you, though it cost me ten nights' watchings.

CLAUDIO

And I, my lord.

DON PEDRO

And you too, gentle Hero?

HERO

I will do any modest office, my lord, to help my cousin to a good husband.

DON PEDRO

And Benedick is not the unhopefullest husband that I know. Thus far can I praise him; he is of a noble strain, of approved valour and confirmed honesty. I will teach you how to humour your cousin, that she shall fall in love with Benedick; and I, with your two helps, will so practise on Benedick that, in despite of his quick wit and his queasy stomach, he shall fall in love with Beatrice. If we can do this, Cupid

7.

Much Ado About Nothing

1. LEO x DC

2. DP i poof

3. DP x DC, LEO CLA  
: HO follow

4. Group put "hands in"  
like in sports!

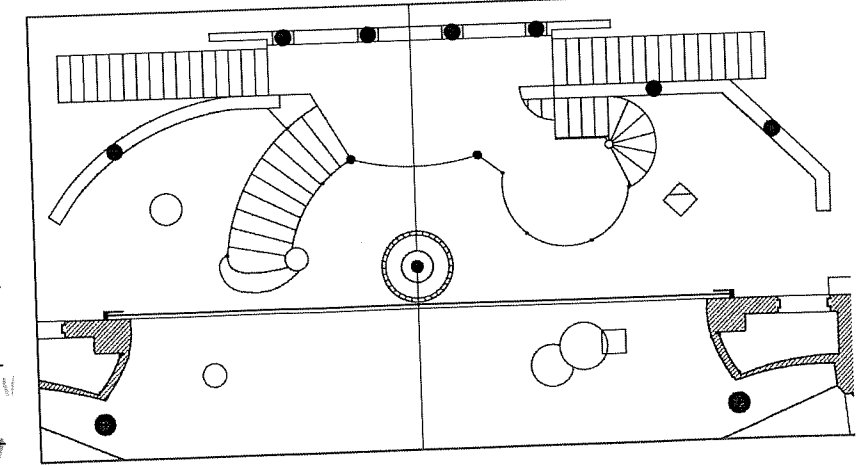
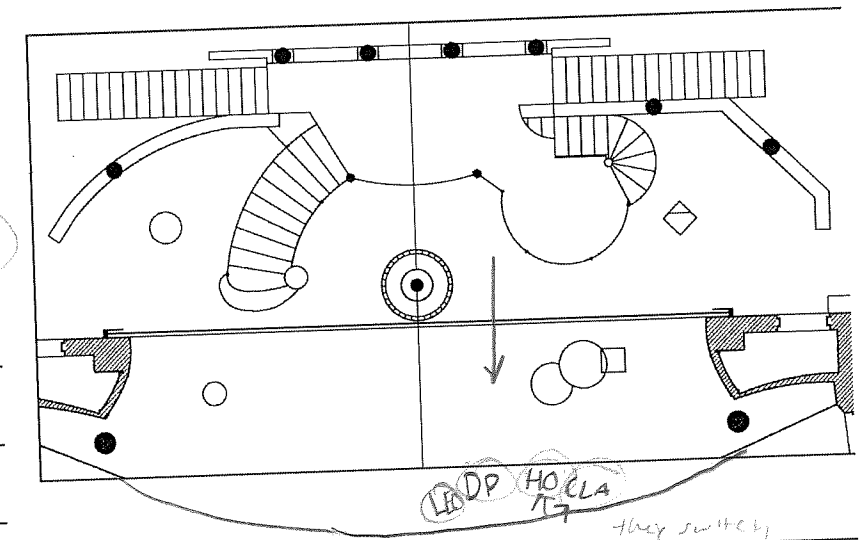
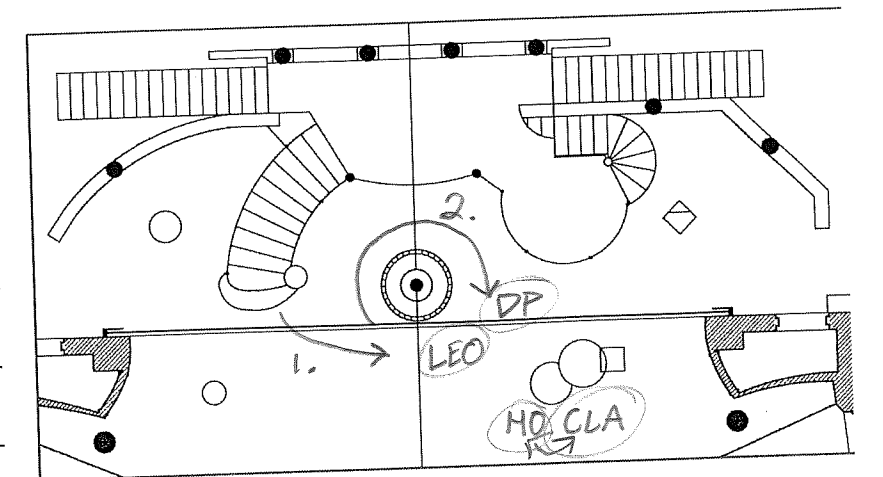

Scene II



*Much Ado About Nothing*

is no longer an archer: his glory shall be ours, for we are the only love-gods. Go in with me, and I will tell you my drift.

*Exeunt*

*Much Ado About Nothing*

L. HO, DP, CLA : LEO  
ex USR

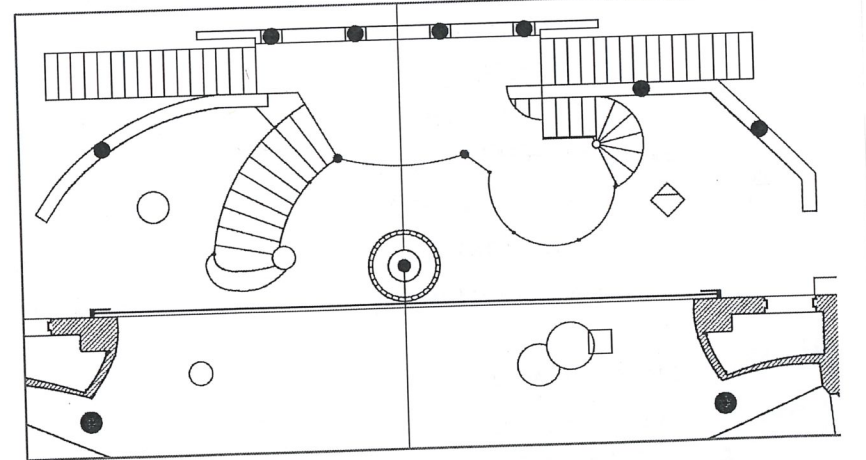
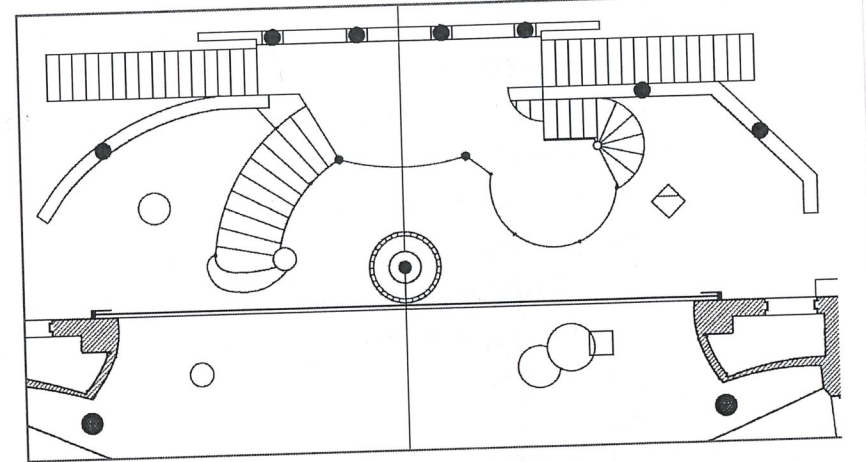
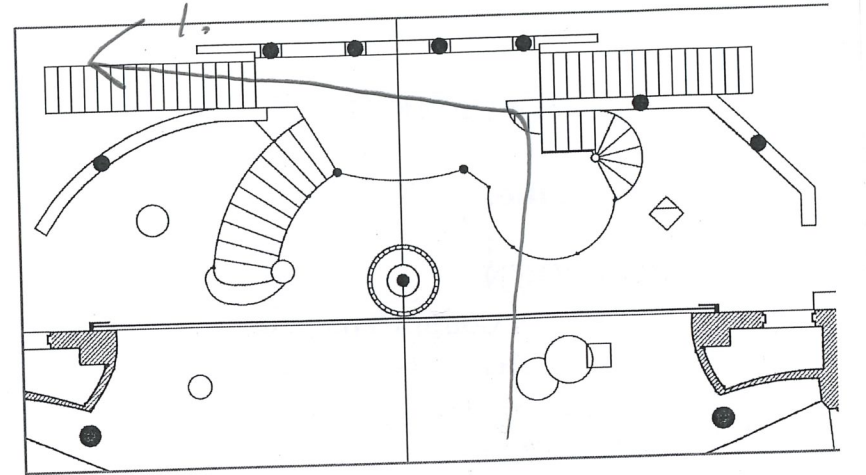

Scene II



ACT II, SCENE II.

The same.

DON JOHN

1. It is so; the Count Claudio shall marry the daughter of Leonata.

BORACHIO

Yea, my lord; but I can cross it.

DON JOHN

2. Any bar, any cross, any impediment will be medicinal to me: I am sick in displeasure to him, and whatsoever comes athwart his affection ranges evenly with mine. How canst thou cross this marriage?

BORACHIO

3. Not honestly, my lord; but so covertly that no dishonesty shall appear in me.

DON JOHN

Show me briefly how.

BORACHIO

I think I told your lordship a year since, how much I am in the favour of Margaret, the waiting gentlewoman to Hero.

DON JOHN

4

I remember.

BORACHIO

I can, at any unseasonable instant of the night, appoint her to look out at her lady's chamber window.

DON JOHN

What life is in that, to be the death of this marriage?

BORACHIO

5. The poison of that lies in you to temper. Go you to the prince your brother; spare not to tell him that he hath wronged his honour in marrying the renowned Claudio-- whose estimation do you mightily hold up--to a contaminated stale, such a one as Hero.

DON JOHN

What proof shall I make of that?

BORACHIO

6. Proof enough to misuse the prince, to vex Claudio, to undo Hero and kill Leonata.

Look you for any other issue?

DON JOHN

Only to despise them, I will endeavour any thing.

1. DJ : BOR ent. DSL, DJ  
Start up SR stairs, BOR  
land in front of stairs
2. DJ step down 3 steps
3. BOR x to SR of poof
4. BOR wander DSL
5. DJ climb stairs to  
top of platform, land UC
6. BOR x to SR, in front  
of stairs, BOR craziness

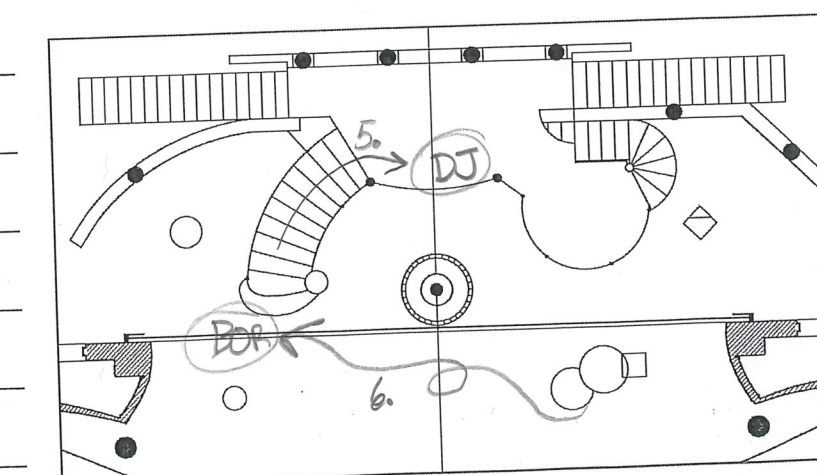
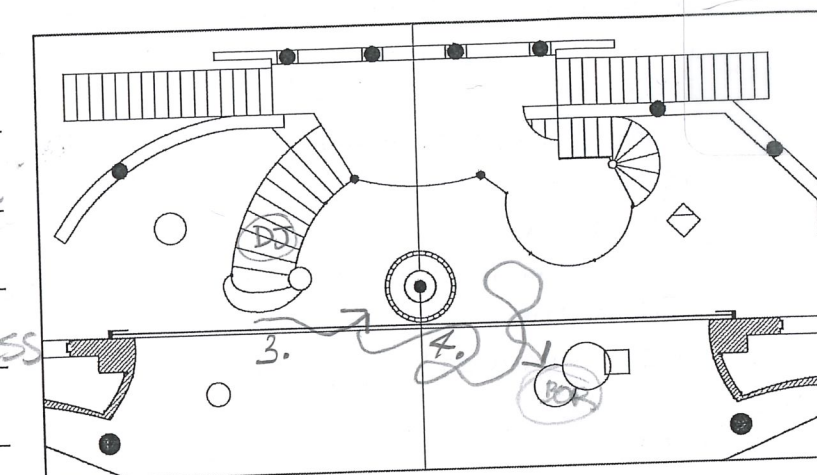
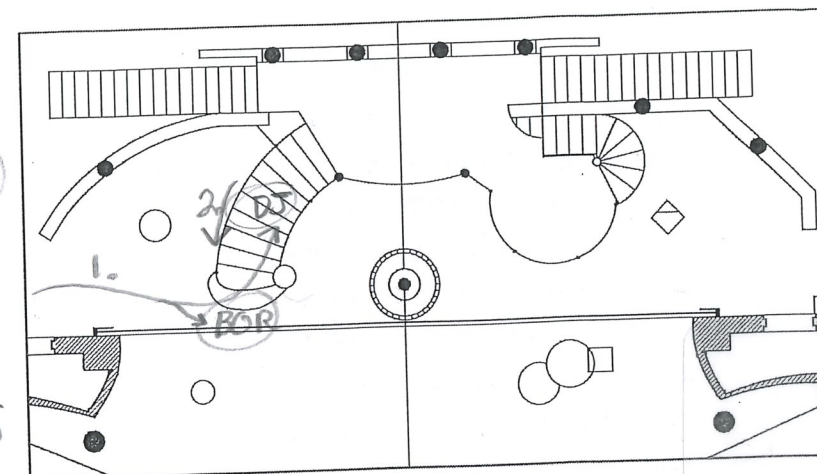

Scene II



Much Ado About Nothing

2.

BORACHIO

1. Go, then; find me a meet hour to draw Don Pedro and the Count Claudio alone: tell them that you know that Hero loves me; intend a kind of zeal both to the prince and Claudio, as,--in love of your brother's honour, who hath made this match, and his friend's reputation, who is thus like to be cozened with the semblance of a maid,-- that you have discovered thus. They will scarcely believe this without trial: offer them instances; which shall bear no less likelihood than to see me at her chamber-window, hear me call Margaret Hero, hear Margaret term me Claudio; and bring them to see this the very night before the intended wedding,--for in the meantime I will so fashion the matter that Hero shall be absent,--and there shall appear such seeming truth of Hero's disloyalty that jealousy shall be called assurance and all the preparation overthrown.

DON JOHN

4.

Grow this to what adverse issue it can, I will put it in practise. Be cunning in the working this, and thy fee is a thousand ducats.

BORACHIO

Be you constant in the accusation, and my cunning shall not shame me.

DON JOHN

I will presently go learn their day of marriage.

Exeunt

Much Ado About Nothing

- 1. BOR laying out the vision, pacing/wandering SR
- 2. BOR BIG in of poof, to fount, stand on lower step
- 3. BOR x DSR, U poof
- 4. BOR leap onto SR side of poof
- 5. BOR ext in fount, ext. USR, DJ exit SR esc

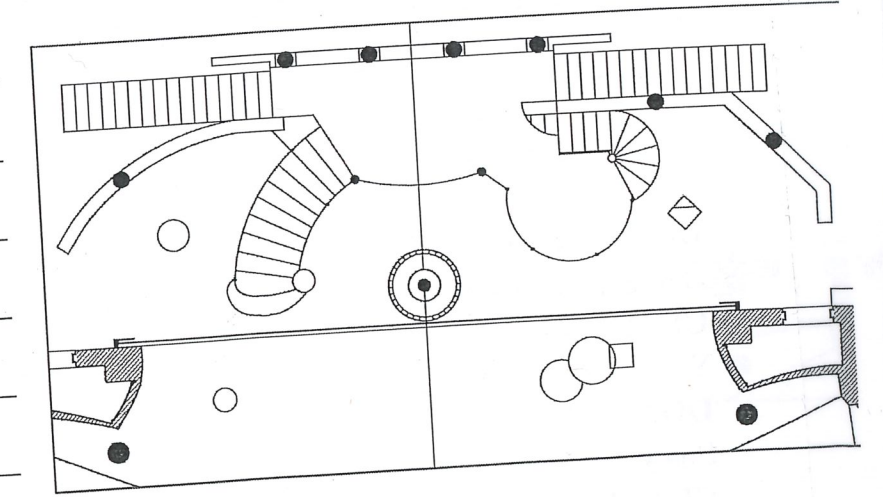
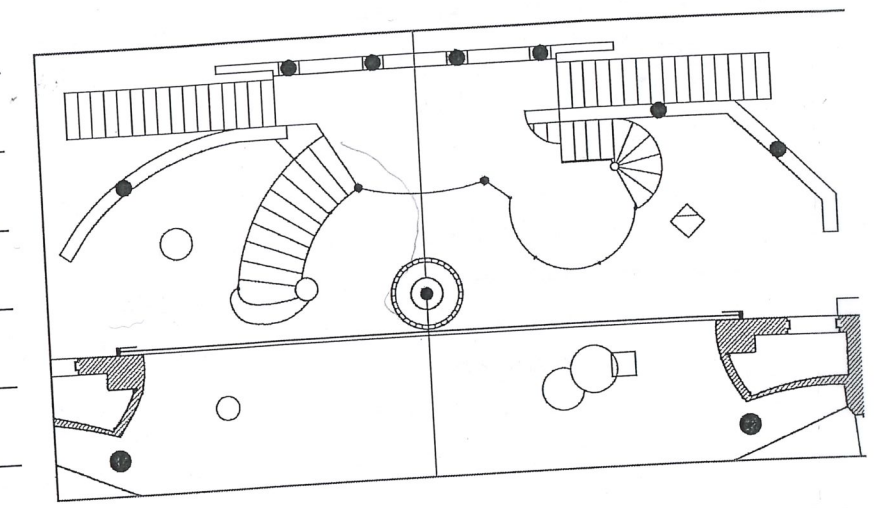
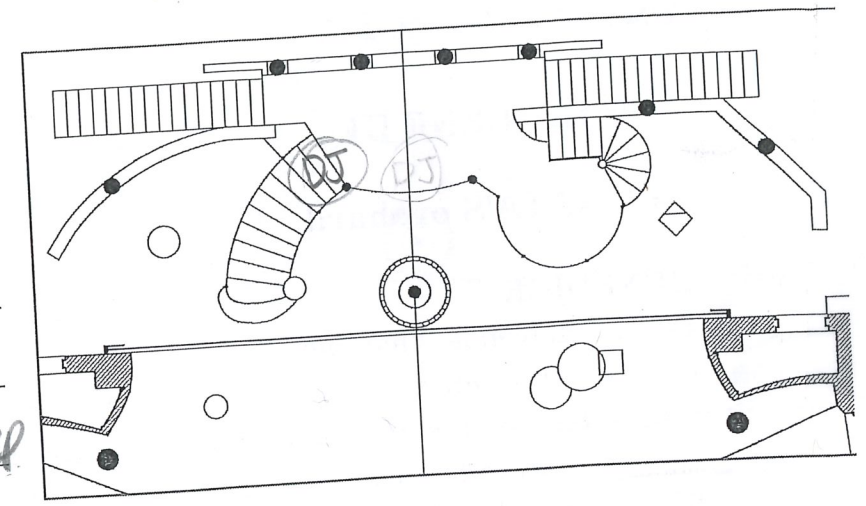

Scene III



Much Ado About Nothing

ACT II, SCENE III.

LEONATA'S orchard.

1. BENEDICK

I do much wonder that one man, seeing how much another man is a fool when he dedicates his behaviors to love, will, after he hath laughed at such shallow follies in others, become the argument of his own scorn by failing in love: and such a man is

2. Claudio. I have known when there was no music with him but the drum and the fife; and now had he rather hear the tabour and the pipe: I have known when he would have walked ten mile a-foot to see a good armour; and now will he lie ten nights awake, carving the fashion of a new doublet. He was wont to speak plain and to the purpose, like an honest man and a soldier; and now is he turned orthography;

3. his words are a very fantastical banquet, just so many strange dishes. May I be so converted and see with these eyes? I cannot tell; I think not: I will not be sworn, but love may transform me to an oyster; but I'll take my oath on it, till he have made an oyster of me, he shall never make me such a fool. One woman is fair, yet I am well;

4. another is wise, yet I am well; another virtuous, yet I am well; but till all graces be in one woman, one woman shall not come in my grace. Rich she shall be, that's certain; wise, or I'll none; virtuous, or I'll never cheapen her; fair, or I'll never look on her; mild, or come not near me; noble, or not I for an angel; of good discourse, an excellent musician, and her hair shall be of what colour it please God. Ha! the prince and Monsieur Love! I will hide me

5. Withdraws

Enter DON PEDRO, CLAUDIO, and LEONATA

DON PEDRO

Come, shall we hear this music?

CLAUDIO

Yea, my good lord. How still the evening is, As hush'd on purpose to grace harmony!

DON PEDRO

See you where Benedick hath hid himself?

CLAUDIO

O, very well, my lord.

Enter BALTHASAR with Music

Much Ado About Nothing

1. BEN ent DSL, X sit on fount.

2. BEN stand, P/D book, X DSR

3. BEN X DSL

4. BEN X UC, sit on poof

5. BEN X DSL, DS of fount

6. BEN X UC, DS of poof

7. BEN X DSR, "hide", X UC "hide", X DSL, P/U book, pose w/ fount, drop squat, hide behind

8. DP, CLA, LEO : BAL ent USR

LEO : CLA X DSL, LEO

sit on fount

BAL X DSR, sit on bench

DP wander UC

BEN: book BAL: ukule

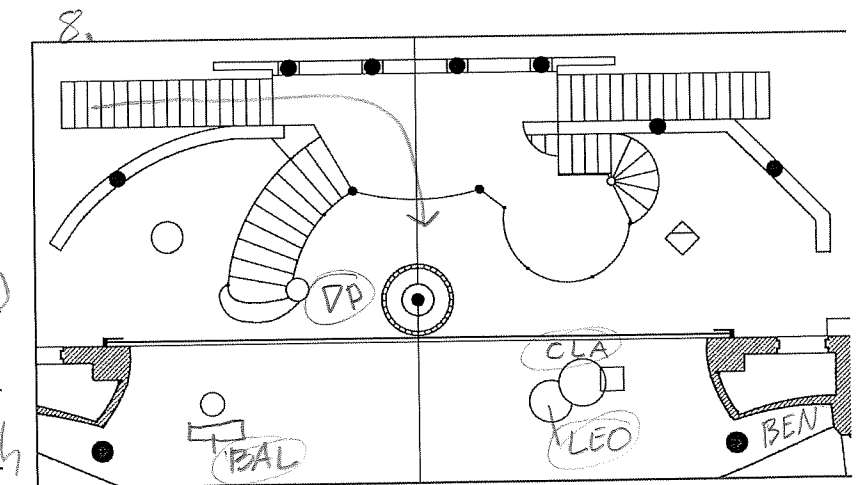
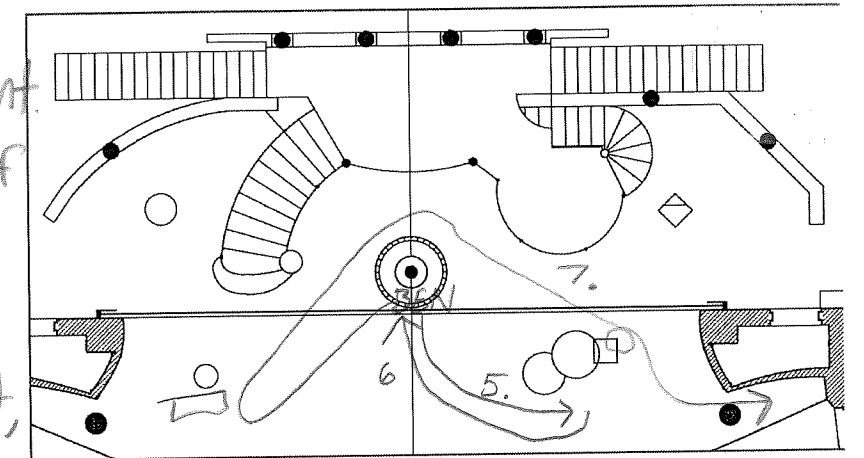
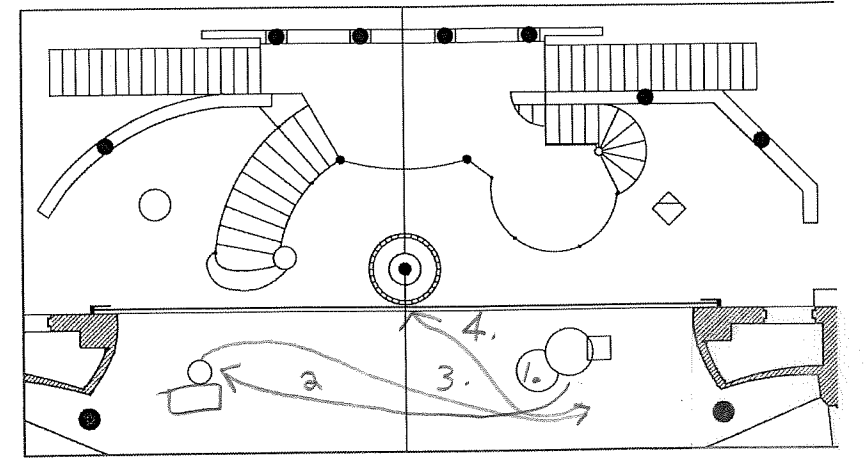



*Much Ado About Nothing*

**DON PEDRO**

Come, Balthasar, we'll hear that song again.

**BALTHASAR**

- ① O, good my lord, tax not so bad a voice  
To slander music any more than once.

**DON PEDRO**

- ② It is the witness still of excellency  
To put a strange face on his own perfection.  
I pray thee, sing, and let me woo no more.

**BALTHASAR**

Because you talk of wooing, I will sing;  
Since many a wooer doth commence his suit  
To her he thinks not worthy, yet he woos,

- 3. Yet will he swear he loves.

**DON PEDRO**

Now, pray thee, come;

Or, if thou wilt hold longer argument,  
Do it in notes.

**BALTHASAR**

Note this before my notes;

There's not a note of mine that's worth the noting.

**DON PEDRO**

Why, these are very crotchets that she speaks;

- 4. Note notes, forsooth, and nothing.

*Air*

**BENEDICK**

Now, divine air! now is his soul ravished! Is it not strange that sheeps' guts should hale souls out of men's bodies?

*The Song*

**BALTHASAR**

*Sigh no more, ladies, sigh no more,  
Men were deceivers ever,  
One foot in sea and one on shore,  
To one thing constant never:  
Then sigh not so, but let them go,*

*Much Ado About Nothing*

1. BAL stand

2. DP step DSR,  
3. BAL sit on bench

4. DP sit on poof

